

Fully aligned  
with the Australian  
Curriculum

The  
PrimaryConnections  
program is supported by  
astronomer, Professor  
Brian Schmidt,  
Nobel Laureate

# Light shows

## Year 5

*Physical sciences*

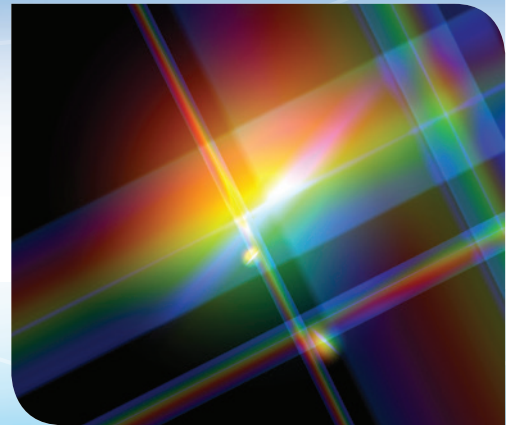

## PrimaryConnections project

<b>Director</b>	Ms Shelley Peers (Australian Academy of Science)
<b>Reference Group</b>	Professor Jenny Graves, AO FAA (Australian Academy of Science) [Chair] Ms Shelley Peers (Australian Academy of Science) ACT Department of Education and Training Australian Council of Deans of Education Australian Curriculum Assessment and Reporting Authority (ACARA) Australian Government Department of Education, Employment and Workplace Relations Australian Literacy Educators' Association Australian Primary Principals Association Australian Science Teachers Association QLD Department of Education, Training and Employment Independent Schools Council of Australia Indigenous Education Consultative Body National Catholic Education Commission NSW Department of Education and Communities NT Department of Education and Training Primary English Teaching Association Australia SA Department for Education and Child Development TAS Department of Education VIC Department of Education and Early Childhood Development WA Department of Education



### Professional learning program

The Primary**Connections** program includes a sophisticated professional learning component and exemplary curriculum resources. Research shows that this combination is more effective than using each in isolation.

Professional Learning Facilitators are available throughout Australia to conduct workshops on the underpinning principles of the program: the Primary**Connections** 5Es teaching and learning model, linking science with literacy, investigating, embedded assessment and collaborative learning.

The Primary**Connections** website has contact details for state and territory Professional Learning Coordinators, as well as additional resources for this unit. Visit the website at:

**[www.primaryconnections.org.au](http://www.primaryconnections.org.au)**

Fully aligned  
with the Australian  
Curriculum

# Light shows

## Year 5

### *Physical sciences*

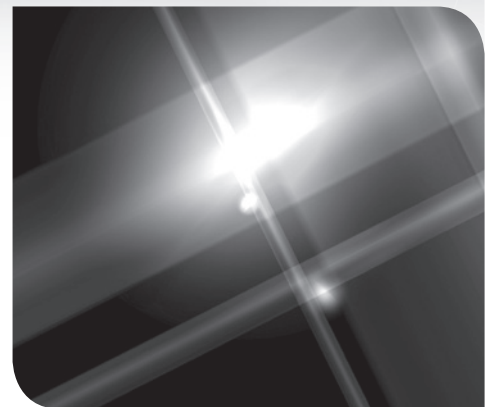

What would our lives be without light? We need it to see everything we do in every moment of the day. We rely on light to read a book, cross the street, admire artwork, watch the sunset and look into faces. Light plays a role in some of our most sophisticated technology. It enables us to play music from a CD or record movies. High-speed optical cable is used in our communications. Lasers are employed in cutting-edge surgery and defence.

The *Light shows* unit is an ideal way to link science with literacy in the classroom. It provides opportunities for students to explore the properties of light and how it enables us to see. Students' thinking about light and its role in our lives and our community will be developed using hands-on activities. Through investigations students explain how objects reflect, absorb and refract light, and how we can use light to meet our needs.

© Australian Academy of Science, December 2012.

### **Copyright for Education**

Educators, academics and students in Australia, people working in associated organisations (such as education authorities, Education Services Australia, the Australian Curriculum, Assessment and Reporting Authority and the Australian Institute for Teaching and School Leadership) and people teaching, studying and learning in schools overseas where the Australian curriculum is taught, may freely use this material for non-commercial educational purposes.

Except as allowed under copyright law or as set out above, you may not reproduce, communicate or otherwise use any of this publication in any of the ways reserved to the copyright owner without the written permission of the Australian Academy of Science.

For permissions, contact the Business Manager, Primary Connections (Australian Academy of Science).

### **Published by the Australian Academy of Science.**

GPO Box 783  
Canberra ACT 2601  
Telephone: (02) 9386 4544  
Fax: (02) 9387 7755  
Email: [pc@science.org.au](mailto:pc@science.org.au)  
[www.primaryconnections.org.au](http://www.primaryconnections.org.au)

Typesetter: Sharyn Raggett  
Font: Helvetica Neue, DIN  
Print house: Daniels Printing Craftsmen  
Cover images: iStockphoto.com

ISBN 978 0 85847 336 2

### **Acknowledgments**

PrimaryConnections is supported by the Australian Government.

Thanks to the trial teachers and students of the trial schools Australia-wide and Fellows of the Australian Academy of Science who contributed to this unit.

All material identified by  is material subject to copyright under the Copyright Act 1968 (Cth) and is owned by the Australian Curriculum, Assessment and Reporting Authority 2012.

**For all Australian Curriculum material except elaborations:** This is an extract from the Australian Curriculum.

**Elaborations:** This may be a modified extract from the Australian Curriculum and may include the work of other authors.

**Disclaimer:** ACARA neither endorses nor verifies the accuracy of the information provided and accepts no responsibility for incomplete or inaccurate information. In particular, ACARA does not endorse or verify that:

- The content descriptions are solely for a particular year and subject;
- All the content descriptions for that year and subject have been used; and
- The author's material aligns with the Australian Curriculum content descriptions for the relevant year and subject.

You can find the unaltered and most up to date version of this material at <http://www.australiancurriculum.edu.au>

This material is reproduced with the permission of ACARA.

### **Disclaimers**

The views expressed herein do not necessarily represent the views of the Australian Government.

These materials are intended for education and training only. Every effort is made to ensure the accuracy of the information presented in these materials. We do not assume any liability for the accuracy or completeness of the information contained within. The Australian Academy of Science accepts no liability or responsibility for any loss or damage whatsoever suffered as a result of direct or indirect use or application of any of these training materials.

# Contents

The Primary <b>Connections</b> program	v
Unit at a glance	1
Alignment with the Australian Curriculum: Science	2
Alignment with the Australian Curriculum: English and Mathematics	7
Teacher background information	8
Introduction to light	8
<b>Lesson ①</b> Light ideas	11
<b>Lesson ②</b> Straight not crooked	20
<b>Lesson ③</b> Mirror, mirror	29
<b>Lesson ④</b> Make way for the light	34
<b>Lesson ⑤</b> Light illusions	42
<b>Lesson ⑥</b> Sneaky spy	50
<b>Lesson ⑦</b> Big shadow, little shadow	58
<b>Lesson ⑧</b> Light thoughts	69
<b>Appendix 1</b> How to organise collaborative learning teams (Year 3—Year 6)	76
<b>Appendix 2</b> How to use a science journal	80
<b>Appendix 3</b> How to use a word wall	82
<b>Appendix 4</b> How to facilitate evidence-based discussions	84
<b>Appendix 5</b> How to write questions for investigation	86
<b>Appendix 6</b> How to conduct a fair test	88
<b>Appendix 7</b> How to construct and use a graph	89
<b>Appendix 8</b> How to use word loops	92
<b>Appendix 9</b> <i>Light shows</i> equipment list	94
<b>Appendix 10</b> <i>Light shows</i> unit overview	98

## Foreword

The Australian Academy of Science is proud of its long tradition of supporting and informing science education in Australia. 'Primary**Connections**: linking science with literacy' is its flagship primary school science program, and it is making a real difference to the teaching and learning of science in Australian schools.

The Primary**Connections** approach has been embraced by schools since its inception in 2004, and there is substantial evidence of its effectiveness in helping teachers transform their practice. It builds teacher confidence and competence in this important area, and helps teachers use their professional skills to incorporate elements of the approach into other areas of the curriculum. Beginning and pre-service teachers find the approach do-able and sustainable. Primary**Connections** students enjoy science more than in comparison classes, and Indigenous students, in particular, show significant increases in learning using the approach.

The project has several components: professional learning, curriculum resources, research and evaluation, and Indigenous perspectives. With the development of an Australian curriculum in the sciences by ACARA in December 2010, it is an exciting time for schools to engage with science, and to raise the profile of primary science education.

Students are naturally curious. Primary**Connections** provides an inquiry-based approach that helps students develop deep learning, and guides them to find scientific ways to answer their questions. The lessons include key science background information, and further science information is included on the Primary**Connections** website ([www.primaryconnections.org.au](http://www.primaryconnections.org.au)).

Science education provides a foundation for a scientifically literate society, which is so important for engagement in key community debates, such as climate change, carbon emissions, and immunisation, as well as for personal decisions about health and well-being. The inquiry approach in Primary**Connections** prepares students well to participate in evidence-based discussions of these and other issues.

Primary**Connections** has been developed with the financial support of the Australian Government and has been endorsed by education authorities across the country. The Steering Committee, comprising the Department of Education, Employment and Workplace Relations and Academy representatives, and the Reference Group, which includes representatives from all stakeholder bodies including states and territories, have provided invaluable guidance and support. Before publication, the teacher background information on science is reviewed by a Fellow of the Academy. All these inputs have ensured an award-winning, quality program.

The Fellows of the Academy are committed to ongoing support for teachers of science at all levels. I commend Primary**Connections** to you and wish you well in your teaching.

### **Professor Suzanne Cory, AC PresAA FRS**

President (2010–2013)

Australian Academy of Science

## The PrimaryConnections program

Primary**Connections** is an innovative program that links the teaching of science and literacy in the primary years of schooling. It is an exciting and rewarding approach for teachers and students, with a professional learning program and supporting curriculum resources. Further information about professional learning and other curriculum support can be found on the Primary**Connections** website: ([www.primaryconnections.org.au](http://www.primaryconnections.org.au))

### The PrimaryConnections teaching and learning model

This unit is one of a series designed to exemplify the Primary**Connections** teaching and learning approach, which embeds inquiry-based learning into a modified 5Es instructional model with the five phases: *Engage*, *Explore*, *Explain*, *Elaborate* and *Evaluate* (Bybee, 1997). The relationship between the 5Es phases, investigations, literacy products and assessment is illustrated below:

Primary**Connections** 5Es teaching and learning model

Phase	Focus	Assessment focus
<b>ENGAGE</b>	Engage students and elicit prior knowledge	<b>Diagnostic assessment</b>
<b>EXPLORE</b>	Provide hands-on experience of the phenomenon	<b>Formative assessment</b>
<b>EXPLAIN</b>	Develop scientific explanations for observations and represent developing conceptual understanding Consider current scientific explanations	<b>Formative assessment</b>
<b>ELABORATE</b>	Extend understanding to a new context or make connections to additional concepts through a student-planned investigation	<b>Summative assessment</b> of the Science Inquiry Skills
<b>EVALUATE</b>	Students re-represent their understanding and reflect on their learning journey, and teachers collect evidence about the achievement of outcomes	<b>Summative assessment</b> of the Science Understanding

More information on Primary**Connections** 5Es teaching and learning model can be found at:  
[www.primaryconnections.org.au](http://www.primaryconnections.org.au)

### Developing students' scientific literacy

The learning outcomes in Primary**Connections** contribute to developing students' scientific literacy. Scientific literacy is considered the main purpose of school science education and has been described as an individual's:

- scientific knowledge and use of that knowledge to identify questions, acquire new knowledge, explain scientific phenomena and draw evidence-based conclusions about science-related issues
- understanding of the characteristic features of science as a form of human knowledge and enquiry
- awareness of how science and technology shape our material, intellectual and cultural environments
- willingness to engage in science-related issues, and with the ideas of science, as a reflective citizen (Programme for International Student Assessment & Organisation for Economic Co-operation and Development [PISA & OECD], 2009).

## Linking science with literacy

PrimaryConnections has an explicit focus on developing students' knowledge, skills, understanding and capacities in science and literacy. Units employ a range of strategies to encourage students to think about and to represent science.

PrimaryConnections develops the literacies of science that students need to learn and to represent their understanding of science concepts, processes and skills. Representations in PrimaryConnections are multi-modal and include text, tables, graphs, models, drawings and embodied forms, such as gesture and role-play. Students use their everyday literacies to learn the new literacies of science. Science provides authentic contexts and meaningful purposes for literacy learning, and also provides opportunities to develop a wider range of literacies. Teaching science with literacy improves learning outcomes in both areas.

## Assessment

Assessment against the year level achievement standards of the Australian Curriculum: Science (ACARA, 2012) is ongoing and embedded in PrimaryConnections units.

Assessment is linked to the development of literacy practices and products. Relevant understandings and skills are highlighted at the beginning of each lesson. Different types of assessment are emphasised in different phases:



**Diagnostic assessment** occurs in the *Engage* phase. This assessment is to elicit students' prior knowledge so that the teacher can take account of this when planning how the *Explore* and *Explain* lessons will be implemented.



**Formative assessment** occurs in the *Explore and Explain* phases. This enables the teacher to monitor students' developing understanding and provide feedback that can extend and deepen students' learning.



**Summative assessment** of the students' achievement developed throughout the unit occurs in the *Elaborate* phase for the Science Inquiry Skills, and in the *Evaluate* phase for the Science Understanding.



## Alignment with the Australian Curriculum: Science

The Australian Curriculum: Science has three interrelated strands—Science Understanding, Science as a Human Endeavour and Science Inquiry Skills—that together ‘provide students with understanding, knowledge and skills through which they can develop a scientific view of the world’ (ACARA, 2012).

The content of these strands is described by the Australian Curriculum as:

Science Understanding	
Biological sciences	Understanding living things
Chemical sciences	Understanding the composition and behaviour of substances
Earth and space sciences	Understanding Earth’s dynamic structure and its place in the cosmos
Physical sciences	Understanding the nature of forces and motion, and matter and energy
Science as a Human Endeavour	
Nature and development of science	An appreciation of the unique nature of science and scientific knowledge.
Use and influence of science	How science knowledge and applications affect people’s lives and how science is influenced by society and can be used to inform decisions and actions
Science Inquiry Skills	
Questioning and predicting	Identifying and constructing questions, proposing hypotheses and suggesting possible outcomes
Planning and conducting	Making decisions regarding how to investigate or solve a problem and carrying out an investigation, including the collection of data
Processing and analysing data and information	Representing data in meaningful and useful ways; identifying trends, patterns and relationships in data, and using evidence to justify conclusions
Evaluating	Considering the quality of available evidence and the merit or significance of a claim, proposition or conclusion with reference to that evidence
Communicating	Conveying information or ideas to others through appropriate representations, text types and modes

 All the material in this table is sourced from the Australian Curriculum.

There will be a minimum of four **PrimaryConnections** units for each year of primary school from Foundation to Year 6—at least one for each Science Understanding sub-strand of the Australian Curriculum. Each unit contains detailed information about its alignment with all aspects of the Australian Curriculum: Science and its links to the Australian Curriculum: English and Mathematics.



## Safety

Learning to use materials and equipment safely is central to working scientifically. It is important, however, for teachers to review each lesson before teaching to identify and manage safety issues specific to a group of students. A safety icon  is included in lessons where there is a need to pay particular attention to potential safety hazards. The following guidelines will help minimise risks:

- Be aware of the school's policy on safety in the classroom and for excursions.
- Check students' health records for allergies or other health issues.
- Be aware of potential dangers by trying out activities before students do them.
- Caution students about potential dangers before they begin an activity.
- Clean up spills immediately as slippery floors are dangerous.
- Instruct students never to taste, smell or eat anything unless they are given permission.
- Discuss and display a list of safe practices for science activities.

## References

Australian Curriculum Assessment and Reporting Authority (ACARA). (2012). *Australian Curriculum: Science*. [www.australiancurriculum.edu.au](http://www.australiancurriculum.edu.au)

Bybee, R.W. (1997). *Achieving scientific literacy: from purposes to practical action*. Portsmouth, NH: Heinemann.

Programme for International Student Assessment & Organisation for Economic Co-operation and Development. (2009). *PISA 2009 assessment framework: key competencies in reading, mathematics and science*. Paris: OECD Publishing.

## Unit at a glance

## Light shows

Phase	Lesson	At a glance
<b>ENGAGE</b>	<b>Lesson 1</b> Light ideas <b>Session 1</b> Illumination <b>Session 2</b> In the dark	To capture students' interest and find out what they think they know about how light from a source forms shadows and can be absorbed, reflected and refracted.  To elicit students' questions about light.
	<b>Lesson 2</b> Straight not crooked <b>Session 1</b> Shining light <b>Session 2</b> The travelling light show	To provide students with hands-on, shared experiences of how light enables us to see objects.
<b>EXPLORE</b>	<b>Lesson 3</b> Mirror, mirror	To provide students with hands-on, shared experiences of how light travels.
	<b>Lesson 4</b> Make way for the light	To provide students with hands-on, shared experiences of how different materials (transparent, translucent or opaque) affect the transmission of light.
	<b>Lesson 5</b> Light illusions	To provide students with hands-on shared experiences of how water refracts light.
<b>EXPLAIN</b>	<b>Lesson 6</b> Sneaky spy	To support students to represent and explain their understanding of how light from a source forms shadows and can be absorbed, reflected and refracted, and to introduce current scientific views.
<b>ELABORATE</b>	<b>Lesson 7</b> Big shadow, little shadow	To support students to plan and conduct an investigation of the height of shadows.
<b>EVALUATE</b>	<b>Lesson 8</b> Light thoughts <b>Session 1</b> Light loop <b>Session 2</b> Shadow puppets	To provide opportunities for students to represent what they know about how light from a source forms shadows and can be absorbed, reflected and refracted, and to reflect on their learning during the unit.

A unit overview can be found in Appendix 10, page 98.

## Alignment with the Australian Curriculum: Science

This *Light shows* unit embeds all three strands of the Australian Curriculum: Science.

The table below lists sub-strands and their content for Year 5. This unit is designed to be taught in conjunction with other Year 5 units to cover the full range of the Australian Curriculum: Science content for Year 5.

For ease of assessment the table below outlines the sub-strands and their aligned lessons.

Strand	Sub-strand	Code	Year 5 content descriptions	Lessons
<b>Science Understanding</b>	<b>Chemical sciences</b>	ACSSU080	Light from a source forms shadows and can be absorbed, reflected and refracted	1–8
<b>Science as a Human Endeavour</b>	<b>Nature and development of science</b>	ACSHE081	Science involves testing predictions by gathering data and using evidence to develop explanations of events and phenomena	1, 4, 5
	<b>Use and influence of science</b>	ACSHE083	Scientific understandings, discoveries and inventions are used to solve problems that directly affect peoples' lives	1, 5, 8
		ACSHE217	Scientific knowledge is used to inform personal and community decisions	4
<b>Science Inquiry Skills</b>	<b>Questioning and predicting</b>	ACSIS231	With guidance, pose questions to clarify practical problems or inform a scientific investigation, and predict what the findings of an investigation might be	1, 2, 5, 6, 7
	<b>Planning and conducting</b>	ACSIS086	With guidance, plan appropriate investigation methods to answer questions or solve problems	2, 3, 5, 6, 7
		ACSIS087	Decide which variable should be changed and measured in fair tests and accurately observe, measure and record data, using digital technologies as appropriate	5, 6, 7
		ACSIS088	Use equipment and materials safely, identifying potential risks	5, 7
	<b>Processing and analysing data and information</b>	ACSIS090	Construct and use a range of representations, including tables and graphs, to represent and describe observations, patterns or relationships in data using digital technologies as appropriate	3, 4, 6, 7
		ACSIS218	Compare data with predictions and use as evidence in developing explanations	5
	<b>Evaluating</b>	ACSIS091	Suggest improvements to the methods used to investigate a question or solve a problem	7
	<b>Communicating</b>	ACSIS093	Communicate ideas, explanations and processes in a variety of ways, including multi-modal texts	2, 3, 4, 5, 6, 8

 All the material in the first four columns of this table is sourced from the Australian Curriculum.

## Interrelationship of the science strands

The interrelationship between the three strands—Science Understanding, Science as a Human Endeavour and Science Inquiry Skills—and their sub-strands is shown below. Sub-strands covered in this unit are in bold.

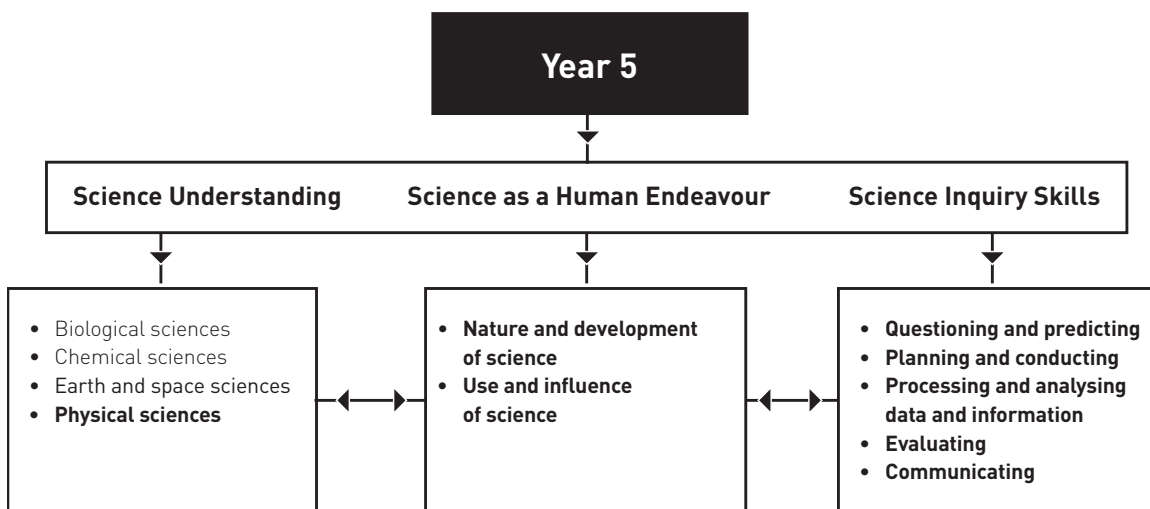

**AC** All the terms in this diagram are sourced from the Australian Curriculum.

## Relationship to overarching ideas

In the Australian Curriculum: Science, six overarching ideas support the coherence and developmental sequence of science knowledge within and across year levels.

In *Light shows* these overarching ideas are represented by:

Overarching idea	Incorporation in <i>Light shows</i>
<b>Patterns, order and organisation</b>	Students identify and describe relationships that underpin the cause and effect of light forming shadows and enabling us to see. Students order and categorise materials according to their light-transmitting properties.
<b>Form and function</b>	Students describe physical properties of light and the materials light encounters, and relate them to their function and use. Students manipulate light by choosing appropriate materials to create a periscope.
<b>Stability and change</b>	Students recognise the stable properties and predictable nature of light, such as travelling in straight lines from a source and how it interacts with different materials.
<b>Scale and measurement</b>	Students measure the effects of light and describe light travelling continuously in a straight line until it encounters objects. Students quantify the height of shadows using formal units of measurement.
<b>Matter and energy</b>	Students use direct experience and observation of rays of light to explain how light can form shadows and be reflected, refracted or absorbed.
<b>Systems</b>	Students learn about the role light plays in our ability to see and relate the properties of materials to the effect they have on light.

## Curriculum focus

The Australian Curriculum: Science is described by year level, but provides advice across four year groupings on the nature of learners. Each year grouping has a relevant curriculum focus.

Curriculum focus Years 3–6	Incorporation in <i>Light shows</i>
<p><b>Recognising questions that can be investigated scientifically and investigating them</b></p>	<p>Students generate questions to explore the properties of light and investigate them through hands-on activities. Using a fair test, they develop claims based on evidence about the variation in height of a shadow.</p>

## Achievement standards

The achievement standards of the Australian Curriculum: Science indicate the quality of learning that students typically demonstrate by a particular point in their schooling, for example, at the end of a year level. These standards will be reviewed regularly by ACARA and are available from the ACARA website.





By the end of this unit, teachers will be able to make evidence-based judgments on whether the students are achieving below, at or above the Australian Curriculum: Science Year 5 achievement standard.

## General capabilities

The skills, behaviours and attributes that students need to succeed in life and work in the 21st century have been identified in the Australian Curriculum as general capabilities. There are seven general capabilities and they are embedded throughout the units. For further information see: [www.australiancurriculum.edu.au](http://www.australiancurriculum.edu.au)

For examples of our unit-specific general capabilities information see the next page.

## Light shows—Australian Curriculum general capabilities

General capabilities	Australian Curriculum description	Light shows examples
<b>Literacy</b>	<p>Literacy knowledge specific to the study of science develops along with scientific understanding and skills.</p> <p>Primary <b>Connections</b> learning activities explicitly introduce literacy focuses and provide students with the opportunity to use them as they think about, reason and represent their understanding of science.</p>	<p>In <i>Light shows</i> the literacy focuses are:</p> <ul style="list-style-type: none"> <li>• science journals</li> <li>• science chat-boards</li> <li>• word walls</li> <li>• tables</li> <li>• ray diagrams</li> <li>• labelled diagrams</li> <li>• procedural texts</li> <li>• graphs</li> <li>• oral presentations.</li> </ul>
 <b>Numeracy</b>	<p>Elements of numeracy are particularly evident in Science Inquiry Skills. These include practical measurement and the collection, representation and interpretation of data.</p>	<p>Students:</p> <ul style="list-style-type: none"> <li>• collect, interpret and represent data in tables</li> <li>• use measurement when collecting data</li> <li>• represent and interpret data in simple graphs.</li> </ul>
<b>Information and communication technology (ICT) competence</b>	<p>ICT competence is particularly evident in Science Inquiry Skills. Students use digital technologies to investigate, create, communicate, and share ideas and results.</p>	<p>Students are given optional opportunities to:</p> <ul style="list-style-type: none"> <li>• use interactive resource technology to view, record and discuss information</li> <li>• use digital technologies to assist in their investigations.</li> </ul>
 <b>Critical and creative thinking</b>	<p>Students develop critical and creative thinking as they speculate and solve problems through investigations, make evidence-based decisions, and analyse and evaluate information sources to draw conclusions. They develop creative questions and suggest novel solutions.</p>	<p>Students:</p> <ul style="list-style-type: none"> <li>• formulate, pose and respond to questions</li> <li>• consider different ways of thinking</li> <li>• develop evidence-based claims.</li> </ul>
<b>Ethical behaviour</b>	<p>Students develop ethical behaviour as they explore principles and guidelines in gathering evidence and consider the implications of their investigations on others and the environment.</p>	<p>Students:</p> <ul style="list-style-type: none"> <li>• ask questions of others respecting each other's point of view.</li> </ul>
 <b>Personal and social competence</b>	<p>Students develop personal and social competence as they learn to work effectively in teams, develop collaborative methods of inquiry, work safely, and use their scientific knowledge to make informed choices.</p>	<p>Students:</p> <ul style="list-style-type: none"> <li>• work collaboratively in teams</li> <li>• listen to and follow instructions to safely complete investigations</li> <li>• participate in discussions.</li> </ul>
 <b>Intercultural understanding</b>	<p>Intercultural understanding is particularly evident in Science as a Human Endeavour. Students learn about the influence of people from a variety of cultures on the development of scientific understanding.</p>	<ul style="list-style-type: none"> <li>• 'Cultural perspectives' opportunities are highlighted where relevant</li> <li>• Important contributions made to science by people from a range of cultures are highlighted where relevant.</li> </ul>

 All the material in the first two columns of this table is sourced from the Australian Curriculum.

## Cross-curriculum priorities

There are three cross-curriculum priorities identified by the Australian Curriculum:

- Aboriginal and Torres Strait Islander histories and cultures
- Asia and Australia's engagement with Asia
- Sustainability.

For further information see: [www.australiancurriculum.edu.au](http://www.australiancurriculum.edu.au)



## Aboriginal and Torres Strait Islander histories and cultures

The PrimaryConnections Indigenous perspectives framework supports teachers' implementation of Aboriginal and Torres Strait Islander histories and cultures in science. The framework can be accessed at: [www.primaryconnections.org.au](http://www.primaryconnections.org.au)

*Light shows* focuses on the Western science way of making evidence-based claims for why we have night and day.

Aboriginal and Torres Strait Islander Peoples might have other explanations for the observed phenomenon of day and night, often referring to the Dreamtime. For example, some groups tell stories of a female Sun who walks across the sky with a bright torch during the day and at night travels in an underground tunnel back to the camp in the East. These stories may serve as reminders to the group about their laws and customs.

For information and activities about Aboriginal and Torres Strait Islander Peoples' use of astronomy, access *Astronomy and Australian Indigenous People* written by Adele Pring from the Astronomical Association of South Australia (<http://www.assa.org.au/media/2912/aaaip.pdf>).

PrimaryConnections recommends working with Aboriginal and Torres Strait Islander community members to access local and relevant cultural perspectives. Protocols for engaging with Aboriginal and Torres Strait Islander community members are provided in state and territory education guidelines. Links to these are provided on the PrimaryConnections website.



## Alignment with the Australian Curriculum: English and Mathematics

Strand	Sub-strand	Code	Year 5 content descriptions	Lessons
English– Language	Language for interaction	ACELA1502	Understand how to move beyond making bare assertions and take account of differing perspectives and points of view	1, 4, 5, 7
	Text structure and organisation	ACELA1504	Understand how texts vary in purpose, structure and topic as well as the degree of formality	1–8
	Expressing and developing ideas	ACELA1512	Understand the use of vocabulary to express greater precision of meaning, and know that words can have different meanings in different contexts	1–8
		ACELA1513	Understand how to use banks of known words, as well as word origins, prefixes, suffixes, to learn and spell new words	1–8
English– Literacy	Interacting with others	ACELY1699	Clarify understanding of content as it unfolds in formal and informal situations, connecting ideas to students' own experiences and present and justify a point of view	1–6
		ACELY1796	Use interaction skills, for example paraphrasing, questioning and interpreting non-verbal cues and choose vocabulary and vocal effects appropriate for different audiences and purposes	1, 3, 4, 5, 7, 8
		ACELY1700	Plan, rehearse and deliver presentations for defined audiences and purposes incorporating accurate and sequenced content and multimodal elements	8
	Interpreting, analysing, evaluating	ACELY1703	Use comprehension strategies to analyse information, integrating and linking ideas from a variety of print and digital sources	5, 6, 7
	Creating texts	ACELY1704	Plan, draft and publish imaginative, informative and persuasive print and multimodal texts, choosing text structures, language features, images and sound appropriate to purpose and audience	8
Mathematics– Measurement and Geometry	Using units of measurement	ACMMG108	Choose appropriate units of measurement for length, area, volume, capacity and mass	5, 7
Mathematics– Statistics and Probability	Data representation and interpretation	ACMSP118	Pose questions and collect categorical or numerical data by observation or survey	5, 7
		ACMSP119	Construct displays, including column graphs, dot plots and tables, appropriate for data type, with and without the use of digital technologies	5, 7
		ACMSP120	Describe and interpret different data sets in context	5, 7

 All the material in the first four columns of this table is sourced from the Australian Curriculum.

Other links are highlighted at the end of lessons where possible. These links will be revised and updated on the website ([www.primaryconnections.org.au](http://www.primaryconnections.org.au)).

# Teacher background information

## Introduction to light

The Sun is the Earth’s primary source of energy, emitting a broad spectrum of electromagnetic radiation, including sunlight. What we call light is a specific type of energy called ‘visible light’ — the light that humans can see.

Electromagnetic radiation can travel through a vacuum and through transparent liquids or solids.

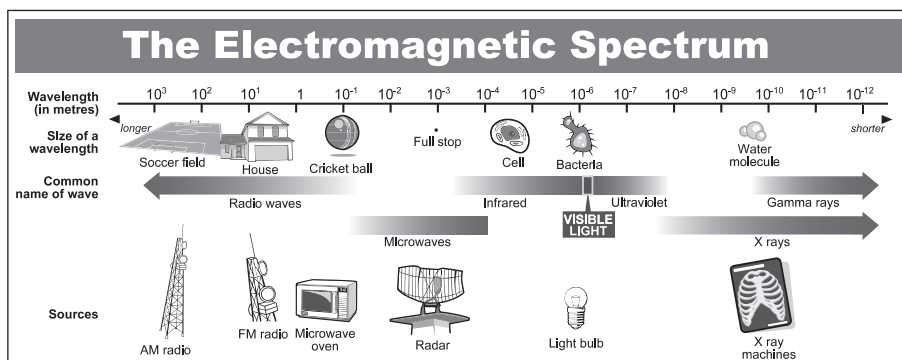
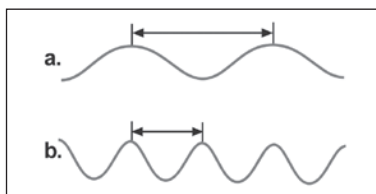

**Diagram of electromagnetic spectrum**

In ordinary situations, such as those encountered in everyday life, electromagnetic radiation, including light, manifests as a wave. However, careful experiments have shown that at a deeper level, electromagnetic radiation also consists of particles, or point-like packets of energy, called ‘photons’. How photons conspire to produce an ordinary wave can only be understood using advanced quantum physics.

Light travels in approximately straight lines called ‘rays’. The ray concept is an approximation, which holds good because the wavelengths of visible light are so small in comparison to everyday length scales. In fact, light passing a sharp edge will diffract a little bit (i.e. bend into the shadow region). This effect is negligible in terms of everyday perception.

Scientists call the distance between the crests of the waves ‘wavelength’, which is measured in metres. Waves with a very short wavelength, for example, gamma rays, will have many crests pass by in one second and are said to have a high frequency. Waves with a long wavelength, for example, radio waves, will have a lower frequency because fewer waves will pass by in one second.



**Diagram of wavelengths**

a. longer wavelength    b. shorter wavelength

Visible light is only a very small part of the electromagnetic spectrum and is important to us because it is this radiation that is detected by the retina and transmitted to the brain by the optic nerve. Other types of electromagnetic radiation include radio waves, microwaves, infra-red radiation, ultraviolet light, X rays and gamma rays. Radios, television sets, microwave ovens and mobile phones are all devices which operate using electromagnetic radiation.

Visible light has a narrow range of wavelengths which are measured in micrometres. A micrometre is 1 millionth of a metre. These different wavelengths are evident as different colours. When all

wavelengths of visible light are present, we see white light. Most transparent substances, for example, water, can spread out or disperse the different wavelengths in a process called refraction, and sometimes we can see the different colours as a rainbow.

When light hits a piece of glass at an angle, the light changes direction (ie. it refracts). The change of direction is different for different colours. Consequently, when light hits a glass prism, the different colours can be seen because they are bent differently. The different bending is due to the fact that the different wavelengths interact with the electrons in the glass differently. The result is that they appear to travel at different speeds.

The rate at which energy is carried by a light wave represents the intensity of the light. We perceive intensity as 'brightness'. Theoretically, light waves from a source could travel forever. The intensity of light from the source will decrease rapidly as we increase our distance from the source because the light will spread out and will usually meet some material, for example, dust in the air. This will cause it to be reflected or scattered or absorbed, and thus the light might not be seen over a large distance.

In a vacuum, for example, interstellar space, all forms of electromagnetic radiation travel at the same speed regardless of their wavelengths. This speed is universally referred to as the 'speed of light'. We know of nothing in our universe which travels faster than light. It races towards us through the vacuum of space at about 300,000 km per second. It takes a fraction of a second for light to cross Australia, about eight minutes for light from the Sun to reach the Earth, over four years for light to reach the next nearest star and 100,000 years for light to get from one side of the Milky Way Galaxy to the other. At such huge, interstellar distances it is customary to refer to distance in 'light years', that is the distance light would travel in one year. Light travels at slightly different speeds through different mediums, such as water or air. When light travels from one medium to the other the change in speed can cause the light to change direction. This refraction of the light can be seen when you view a pencil in water.

Energy cannot be created or destroyed; therefore light has its origins in other forms of energy. The Sun changes most nuclear energy into heat energy and light energy. Some things are sources of light, such as the Sun or a burning candle. These are called primary light sources. Primary light sources are things that change another form of energy into light energy. For example:

- In the Sun, nuclear energy is changed into light energy.
- In a fire, or in glow-worms and glow sticks (cyalume sticks), chemical energy is changed into light energy.
- In light bulbs, lightning and computer screens, electrical energy is changed into light energy.

Most things we see are secondary light sources which reflect the light of a primary light source to our eyes. For example, the light from the lamp (primary) is reflected off the book (secondary) to our eyes and so we are able to see the book. The Moon appears to be a primary light source but it is actually a secondary light source because it reflects light from the Sun to our eyes.

When light from primary sources hits surfaces it can be reflected, transmitted (let through) or absorbed (transformed into heat energy). Different surfaces reflect, transmit or absorb light in different ways. Some surfaces are very smooth and even. These reflect light in an ordered way and appear to be shiny. Other surfaces are more irregular. They reflect light in a scattered way and appear matt or dull. Some surfaces, for example, glass, transmit most light, reflecting very little, and thus appear transparent.

When a surface or object is coloured all the colours of the visible light are absorbed except for the colour of the object which is reflected. For example, a red object absorbs all colours,

except red, which is reflected. Thus the object appears red. Black surfaces absorb all colours and reflect the least light. White surfaces reflect all colours and absorb the least light.

When the reflected light hits the receptors in our eyes our brain puts together the three-dimensional images we see of the world.

The study of light opens up some fascinating areas for further study. Examples include lasers, optical fibres, microscopes, telescopes, cameras and holograms. Scientists are also investigating an artificial eye.

## Students' conceptions

Taking account of students' existing ideas is important in planning effective teaching approaches which help students learn science. Students develop their own ideas during their experiences in everyday life and might hold more than one idea about an event or phenomenon.

Some students might think that light is not considered to 'travel'; rather it is thought to just exist in space. They also might think that light from weak sources doesn't travel as far as light from strong sources. In fact, all light travels from its source in all directions, regardless of its intensity, unless interrupted by matter, such as air, water or an object, where it is reflected, transmitted or absorbed.

There are numerous non-scientific conceptions around the reasons we can see objects. Some students might think that sight or light travels from our eye to the objects we look at or that light remains on the objects so that we can see them. They might have no conception that light from a source such as the Sun is reflected from the object into our eyes so that we can see it.

Students might also think that owls, bats and cats can see in complete darkness and that humans also can see (not well) in complete darkness if we wait a while for our eyes to adjust. When there is minimal light our pupils widen to make better use of the available light. No animal can see in the complete absence of light. Nocturnal animals, for example, owls, have very light-sensitive eyes which allow them to see when there is very little light. However, because they are so sensitive to light they cannot stand the brightness of daylight.

Non-scientific conceptions about the behaviour of light are common. Students might think that light only bounces off luminous objects or very shiny ones, for example, mirrors. Light reflects off shiny surfaces in an ordered way. Light also reflects from dull surfaces but in a more scattered way.

## References

- Cakicki, Y. & Yavuz, G. (2010). 'The effect of constructive science teaching on 4th grade students' understanding of matter', *Asia-Pacific Forum on Science Learning and Teaching*, Volume 11(2), Article 13.
- Hapkiewicz, A. (1992). 'Finding a List of Science Misconceptions', *MSTA Newsletter*, 38 (Winter'92), pp. 11–14.
- Krnel, D., Watson, R., and Glazar, S. (1998). 'Survey of research related to the development of the concept of matter', *International Journal of Science Education*, 20 pp. 257–289.
- Skamp, K. (Ed.). (2012). *Teaching Primary Science Constructively* (4th Edn). South Melbourne: Cengage Learning Australia.

To access more in-depth science information in the form of text, diagrams and animations, refer to the **PrimaryConnections** Science Background Resource which has now been loaded on the **PrimaryConnections** website:  
[www.primaryconnections.org.au/science-background-resource](http://www.primaryconnections.org.au/science-background-resource).

**Note:** This background information is intended for the teacher only.

# Lesson 1 Light ideas

## AT A GLANCE

To capture students' interest and find out what they think they know about how light from a source forms shadows and can be absorbed, reflected and refracted.

To elicit students' questions about light.

### Session 1 Illumination

Students:

- discuss what they think they know about light
- share ideas using a think-box strategy
- record ideas on the science chat-board.

### Session 2 In the dark

Students:

- discuss being in the dark
- contribute ideas about what enables us to see.

## Lesson focus

The focus of the *Engage* phase is to spark students' interest, stimulate their curiosity, raise questions for inquiry and elicit their existing beliefs about the topic. These existing ideas can then be taken account of in future lessons.

## Assessment focus



**Diagnostic assessment** is an important aspect of the *Engage* phase. In this lesson you will elicit what students already know and understand about:

- how light from a source forms shadows and can be absorbed, reflected and refracted.

You will also monitor their developing science inquiry skills (see page 3).

## Key lesson outcomes

### Science

Students will be able to represent their current understanding as they:

- describe how light travels
- discuss how light enables our eyes to see
- describe and visually represent their understanding of reflection, absorption and refraction of light.

### Literacy

Students will be able to:

- contribute to discussions about dark and light
- record ideas using a think-box strategy
- contribute to a science chat-board and word wall.

This lesson also provides opportunities to monitor the development of students' general capabilities (highlighted through icons, see page 5).

## Session 1 Illumination

### Equipment

#### FOR THE CLASS

- class science journal
- science chat-board
- team roles chart
- team skills chart
- word wall
- 1 enlarged copy of 'My thoughts' (Resource sheet 1)
- self-adhesive notes
- 6 large sheets of paper or cardboard (see 'Preparation')
- 5 shoeboxes or similar (see 'Preparation')
- 1 torch

#### FOR EACH TEAM

- role wristbands or badges for Director, Manager and Speaker
- each team member's science journal
- 1 copy of 'My thoughts' (Resource sheet 1) per team member
- glue
- marking pens
- scissors
- 1 large sheet of paper or cardboard (eg, butcher's paper or poster cardboard)

### Preparation

- Read 'How to organise collaborative learning teams (Year 3–Year 6)' (Appendix 1). Display an enlarged copy of the team skills chart and the team roles chart in the classroom. Prepare role wristbands or badges and the equipment table.
- Read 'How to use a science journal' (Appendix 2).
- Read 'How to use a word wall' (Appendix 3).
- Prepare an enlarged copy of 'My thoughts' (Resource sheet 1).
- Cut a slit in the lids of five shoeboxes or similar for use as think-boxes in Lesson step 3. Label the boxes: Question 1, Question 2, Question 3, Question 4 and Question 5.

- Prepare five large sheets of paper (join two A3 sheets together or use butcher's paper), writing one of the five questions below on each sheet:
  1. How does light help us to see?
  2. How does light travel and how far does it travel?
  3. What is a shadow?
  4. What happens when light from a torch hits:
    - black card?
    - a mirror?
  5. Draw what you see when a glass of water has a spoon in it.
- Record the title 'Word wall' on the sixth sheet.
- To support students to organise their ideas, display these charts so that you and your students can record keywords, pictures, questions, ideas and reflections on each chart using self-adhesive notes. Collectively, these charts are the science chat-board for this unit.
- *Optional:* Colour-code the questions and self-adhesive notes to identify the different sections of the science chat-board or use different colours to represent questions, keywords, ideas and thoughts.
- Begin collecting mirrors approximately 8 cm x 5 cm in size (see Lesson 3).

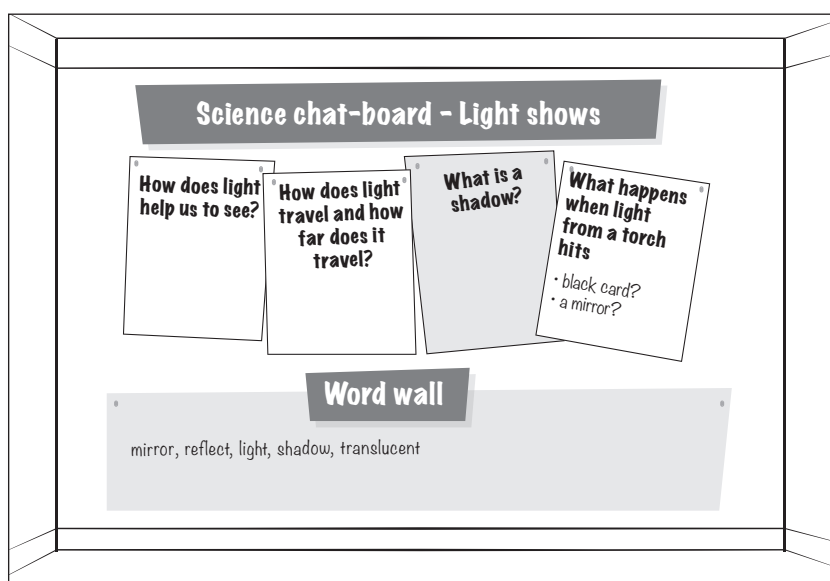

Science chat-board sample

## Lesson steps



- 1 Shine a torch on an object or on the wall and discuss the light by asking questions, such as:
  - What can you see?
  - How do we know the light is there?
  - What happens when you try to hold the light?
  - How could you change the light?

- 2 Introduce the enlarged copy of 'My thoughts' (Resource sheet 1) and discuss each question.
- 3 Introduce the five think-boxes that match each question and explain that students are going to work individually to record their ideas about the five questions. Explain to students that this is an anonymous activity and they should not write their name on their responses.
- 4 Model how to write and draw a response to each question, cut along the dotted lines so that there are five responses, fold each one and place in the matching think-box.



- 5 Allow students time to complete the resource sheet and place their responses in the matching think-box.

**Note:** Do not correct students' answers as this is an opportunity for diagnostic assessment of students' ideas.

- 6 Explain that students will be working in collaborative learning teams to categorise and record the responses from one of the think-boxes.

If students are using collaborative learning teams for the first time, introduce and explain the team skills chart and the team roles chart. Explain that students will wear role wristbands or badges to help them (and you) know which role each member has. Draw students' attention to the equipment table and discuss its use. Explain that this table is where Managers will collect and return equipment.

- 7 Form teams and allocate roles.



- 8 When all responses have been placed in the corresponding think-box, ask five Directors to take one think-box each and share its enclosed responses equally with another Director (who did not select a box).



- 9 Ask students to take turns to read the responses and contribute to sorting them into categories. Ask each Director to paste the responses onto a large sheet of paper in their categories.

**Note:** Using think-boxes is a way to elicit students' conceptions in an anonymous and non-judgmental way. The analysis and sorting of the responses allows for discussion and appreciation that there can be a range of views and understanding of the concept. The role of the teacher is to question and ensure that different views are clarified and understood by everyone, and to assist teams to form and name the categories.

- 10 Introduce the class science journal and discuss its purpose and features. Ask each team to present their findings to the class and record a summary of students' responses to each question in the class science journal.

### Literacy focus

#### Why do we use a science journal?

We use a **science journal** to record what we see, hear, feel and think so that we can look at it later.

#### What does a science journal include?

A **science journal** includes dates and times. It might include written text, drawings, measurements, labelled diagrams, photographs, tables and graphs.



- 11 Introduce the science chat-board and discuss its purpose and features.

### Literacy focus

#### Why do we use a science chat-board?

A **science chat-board** is a display area where we share our changing questions, ideas, thoughts and findings about a science topic.

#### What does a science chat-board include?

A **science chat-board** might include dates and times, written text, drawings, measurements, labelled diagrams, photographs, tables and graphs.



- 12 Display the response sheets to each of the five questions from the think-box activity on the science chat-board or around the classroom. Elicit students' questions about light and record them on the science chat-board.

**Note:** These response sheets will represent students' current understanding about light at the beginning of the unit. As the unit progresses, students will collect evidence and information about light. Encourage students to use this evidence to change, confirm and provide reasons for their understanding of light by adding their thoughts to the science chat-board. For example, students might use different-coloured paper or self-adhesive notes to cover their initial thoughts about light.

- 13 Introduce the word wall and discuss its purpose and features. Record key vocabulary about light on the word wall section of the science chat-board.

### Literacy focus

#### Why do we use a word wall?

We use a **word wall** to record words we know or learn about a topic. We display the word wall in the classroom so that we can look up words we are learning about and see how they are spelled.

#### What does a word wall include?

A **word wall** includes a topic title or picture and words that we have seen or heard about the topic.

*Optional:* Organise a schedule for students to contribute to the science chat-board to ensure all students have time and the opportunity to make regular contributions.

## Curriculum links

### Mathematics

- Sort and group blocks into categories and describe the reasons for the groupings.

# My thoughts

Use drawings and words to show what you think about these questions.

## 1. How does light help us to see?

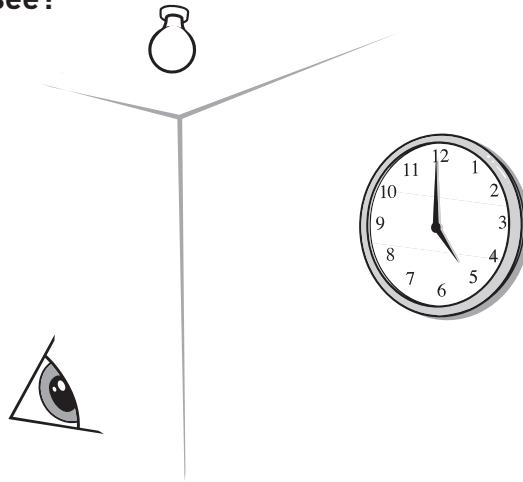

Use arrows to show your answer

## 2. How does light travel and how far does it travel?

## 3. What is a shadow?

## 4. What happens when light from a torch hits

- black card?
- a mirror?

## 5. Draw what you see when a glass of water has a spoon in it.

# Session 2 In the dark

## Equipment

### FOR THE CLASS

- class science journal
- science chat-board
- word wall
- 1 enlarged copy of 'In the dark' (Resource sheet 2)
- self-adhesive notes

### FOR EACH STUDENT

- student science journal
- 1 copy of 'In the dark' (Resource sheet 2)

## Preparation

- Prepare an enlarged copy of 'In the dark' (Resource sheet 2).
- *Optional:* Display 'In the dark' (Resource sheet 2) on an interactive whiteboard or a computer connected to a projector. Check the PrimaryConnections website to see if an accompanying interactive resource has been developed ([www.primaryconnections.org.au](http://www.primaryconnections.org.au)).

## Lesson steps



- 1 Darken the room. Ask students to cover their eyes with their hands to exclude as much light as possible. Ask students to think about a place without light and ask questions, such as:
  - Can you describe a place that is really dark? (For example, a cave.)
  - What could you see?
  - How did you feel?

**Note:** To enable students to experience a totally dark place, teachers might like to create such a place in the classroom by having blankets or sheets for draping over desks or a large table in a corner covered with thick blankets that touch the floor. (A totally dark place is where you cannot see your hand in front of your face.)

- 2 Introduce an enlarged copy of 'In the dark' (Resource sheet 2) and discuss each statement in the table with the class. Discuss the purpose and features of a table.

### Literacy focus

#### Why do we use a table?

We use a **table** to organise information so that we can understand it more easily.

#### What does a table include?

A **table** includes a title, columns with headings and information organised under each heading.



- 3 Ask students to individually complete the sheet by ticking 'Yes', 'No' or 'I'm not sure' for each of the statements.

**Note:** This is an opportunity for you to diagnose students' current conceptions. Responses 1 and 5 are the responses that align with scientists' ideas. In the Engage phase, do not provide any formal definitions or correct any answers as the purpose is to elicit students' prior knowledge.



- 4 Ask students to share their ideas with a partner and discuss similarities and differences. Ask students to paste 'In the dark' (Resource sheet 2) in their science journal.



- 5 Using the enlarged copy of 'In the dark' (Resource sheet 2), record as a tally the students' responses to each of the statements. Ask one student to record the tally on an A4 copy. Place the large copy on the science chat-board and the A4 copy in the class science journal.



- 6 Discuss with students their ideas and thoughts arising from the 'In the dark' activity and add to the five question charts on the science chat-board. Preface recorded ideas with 'We think...' to indicate these are initial thoughts. Ask students what things they are wondering about and explain that during the unit they will explore and investigate light and try to find answers to their questions.
- 7 Update the word wall section of the science chat-board using self-adhesive notes with key vocabulary and images used during the 'In the dark' activity.
- 8 Update the science chat-board with words and images.

# In the dark

Name: \_\_\_\_\_ Date: \_\_\_\_\_

What do you think will happen when the boy switches off the light in this room that has no windows?

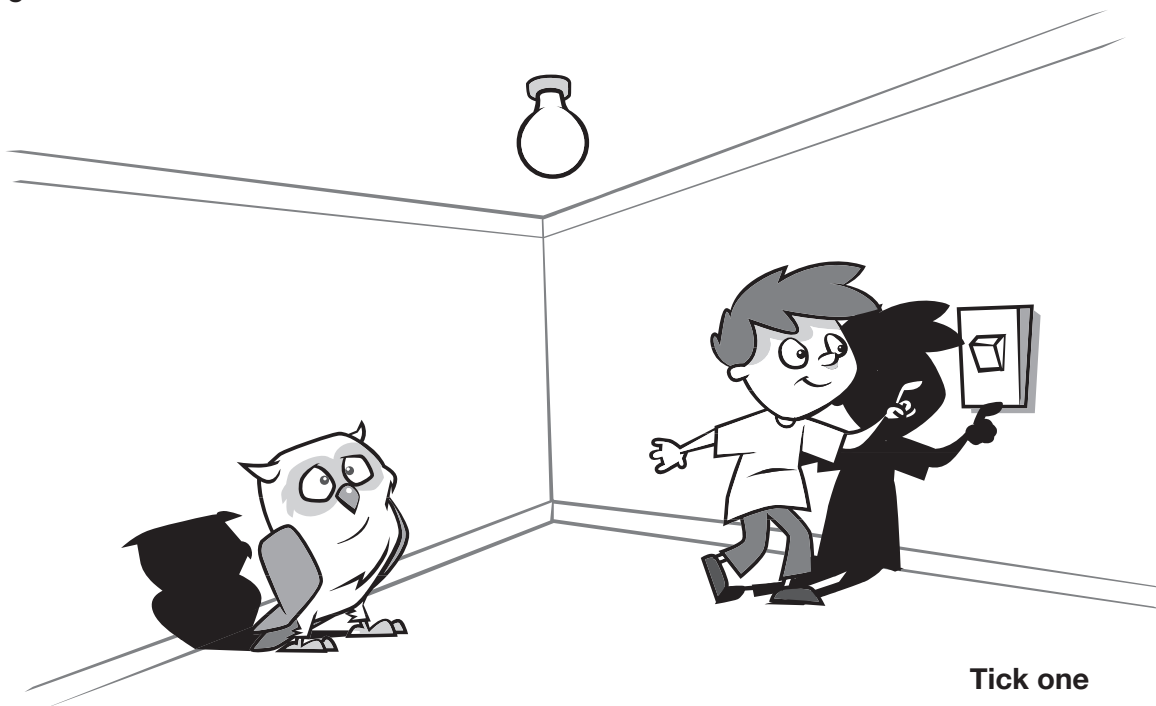

Tick one

	Yes	No	I'm not sure
1. It will be dark in the room and the boy won't be able to see the owl.			
2. The boy will see the owl inside the room because the owl is white.			
3. The boy's eyes will adjust to the dark and then he will be able to see the owl.			
4. The boy will only be able to see the owl's eyes because its eyes will shine in the dark.			
5. The boy will need a torch or candle to be able to see the owl.			
6. When the room is dark the boy and the owl will still cast a shadow.			

# Lesson 2 Straight not crooked

## AT A GLANCE

To provide students with hands-on, shared experiences of how light enables us to see objects.

### Session 1 Shining light

Students:

- make a peek box to demonstrate how we see objects
- draw a ray diagram showing how light travels through a peek box.

### Session 2 The travelling light show

Students:

- compile a list of light sources
- explore how light travels in straight lines
- investigate the size and direction of shadows.

## Lesson focus

The *Explore* phase is designed to provide students with hands-on experiences of the science phenomenon. Students explore ideas, collect evidence, discuss their observations and keep records, such as science journal entries. The *Explore* phase ensures all students have a shared experience that can be discussed and explained in the *Explain* phase.

## Assessment focus



**Formative assessment** is an ongoing aspect of the *Explore* phase. It involves monitoring students' developing understanding and giving feedback that extends their learning. In this lesson you will monitor students' developing understanding of:

- how light travels in straight lines and that shadows are formed when light is blocked.

You will also monitor their developing science inquiry skills (see page 3).

## Key lesson outcomes

### Science

Students will be able to:

- demonstrate how to modify a peek box to see an object
- describe how objects reflect light into our eyes allowing the objects to be seen
- draw a ray diagram to demonstrate that light travels in straight lines
- describe how a shadow is formed by blocking light.

### Literacy

Students will be able to:

- represent their thinking by using key vocabulary related to light
- understand the purpose and features of a ray diagram
- discuss observations of light and shadows
- understand the purpose and features of a labelled diagram
- record ideas about light and shadows.

This lesson also provides opportunities to monitor the development of students' general capabilities (highlighted through icons, see page 5).

## Teacher background information

We see objects only when light travels from them to our eyes. These objects might be primary light sources which give out their own light, such as the Sun, an electric light or a candle, or they might be secondary light sources which reflect light to the eye. For example, this page is a secondary source which you are able to read because it is reflecting the light from a primary light source, such as the sunlight coming through a window or an electric light. Once our eyes detect the light, information is transferred through the optic nerve to the brain, which then interprets the signals from the eye as an image of the object. Take away the light source or stop the light from reaching your eyes and you will no longer be able to see the object; it still exists, but you can no longer see it.

Also, it doesn't reflect the light that is absorbed by the black print. Our eyes and brain recognise the difference. If the print was red, then our eyes and brain would recognise that, from the print, red light was reflected, while from the rest of the paper all colours (white light) are reflected.

Ray diagrams use lines to show light travelling. The lines are straight because light travels in a straight line. Arrowheads show the direction of travel.

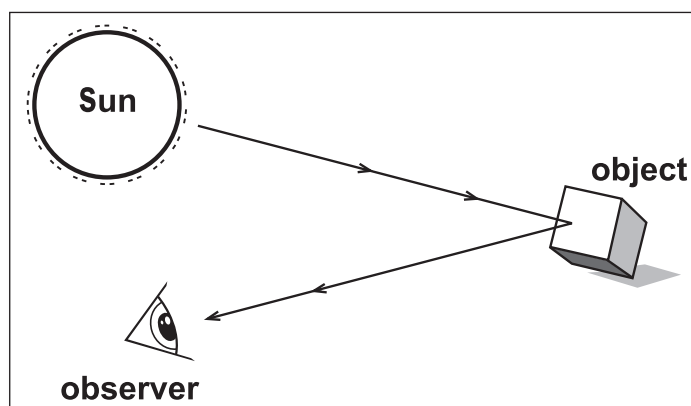

How we see

Shadows are formed because light does not go around objects and light up areas behind them. Light travels in approximately straight lines. Careful examination shows that near edges, there are changes in the light that can be attributed to the wave properties of light. The light appears to bend slightly as it passes near a sharp edge.

Shadows are dark shapes created when an object blocks out light. Materials that block out light are opaque, while materials that allow light to pass through them are transparent. The shape of a shadow is affected by:

- the shape of the object blocking the light
- how close the object is to the light source
- the position of the light source relative to the object, for example, whether it is above or at the same level as the object.

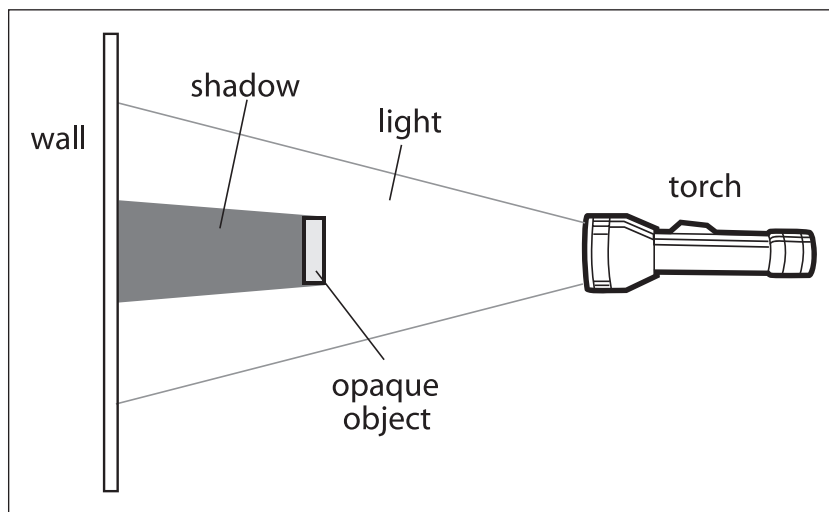

**Casting shadows**

When the position of the light source is right above the object, the object will cast a short shadow on the ground. As the light source moves downwards, the object will cast a longer shadow. This is why when the Sun is directly overhead, people and objects cast very small, short shadows. In the morning and afternoon, however, when the Sun is low on the horizon, they cast very long shadows.

### Students' conceptions

Some students might think that we see objects because 'vision' comes out of our eyes and strikes the object. Another non-scientific idea is that an image comes directly from the object to our eyes. However, it is the light reflecting off the object into our eyes that allows us to see. When the reflected light reaches our eyes, our brain interprets it as the images we see.

Some students might think that shadows are entities independent of light, in other words light allows shadows to be seen, rather than shadows being a result of absence of light. Students might also think that shadows are reflections of dark light. Students might think light on an object 'triggers' the production of a shadow that travels from the object onto the wall or floor where it is seen.

Some students might be confused about the difference between shadows and reflections, for example, drawing a face in a drawing of their shadow.



# Session 1 Shining light

## Equipment

### FOR THE CLASS

- class science journal
- science chat-board
- team roles chart
- team skills chart
- word wall
- 1 cardboard box (eg, a shoe or cereal box) (see 'Preparation')
- self-adhesive notes

### FOR EACH TEAM

- role wristbands or badges for Director, Manager and Speaker
- each team member's science journal
- 1 cardboard box (eg, a shoe or cereal box) (see 'Preparation')
- collection of small objects (eg, toys) (see 'Preparation')
- 1 torch

## Preparation

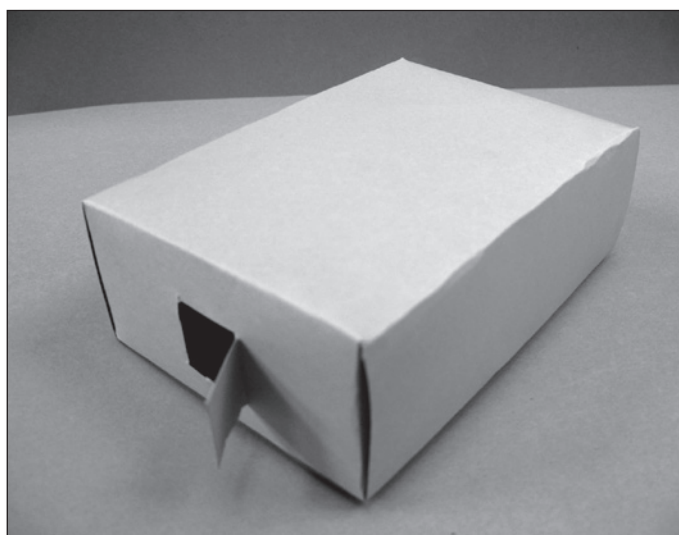

- Prepare a peek box for the class and one for each team by using a shoe or cereal box large enough to place a small object in, with a removable or folding lid, and with a flap cut in one end to peek through.
- Collect a set of small objects that can be placed easily, one at a time, into the box. Provide objects of different colours and textures.



**Partially complete peek box**

- On a blank page in the class science journal write these sentence starters for students to use when they reflect on their learning in this lesson:
  - Today we...
  - I learned that...
  - Things I'm not sure about are...
  - Things I'm interested in finding out about are...

## Lesson steps

- 1 Review the previous session using the science chat-board.
- 
 2 Discuss with students how they think they see by using a sample object and asking questions, such as:
  - What helps you to see this object?
  - What could help you see this object in the dark?
- 
 3 Introduce a partially completed peek box that you have prepared, and show the flap cut into one end. Explain that there is an object inside the box but when you look through the flap you cannot see it. Ask students to think about what could be done to make it possible to see the object without removing the lid.
- 4 Explain that students will be working in collaborative learning teams, with a similar peek box, to investigate the best way to see the object in the box without removing the lid or opening the box. Explain that students will also draw a ray diagram to represent the path of light that helps them to see the object.
- 5 Discuss the purpose and features of a ray diagram.

### Literacy focus

#### Why do we use a ray diagram?

We use a **ray diagram** to show the path of light rays from a light source.



#### What does a ray diagram include?

A **ray diagram** includes arrows showing where the light travels.

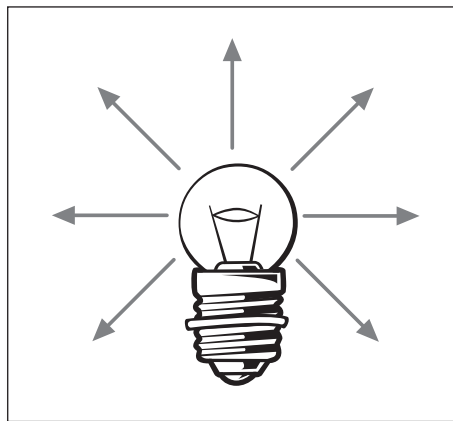
- 6 Model in the class science journal how to draw rays showing the path of light from a light source.



**Example of rays drawn to show path of light**

- 7 Form teams and allocate roles. Ask Managers to collect team equipment.
- 

 8 Encourage teams to investigate with different objects placed in the box and with the same object placed in different positions, such as at the far end of the box, in the middle or closer to the peephole. Remind students to take turns so that everyone has the opportunity to look at each object.

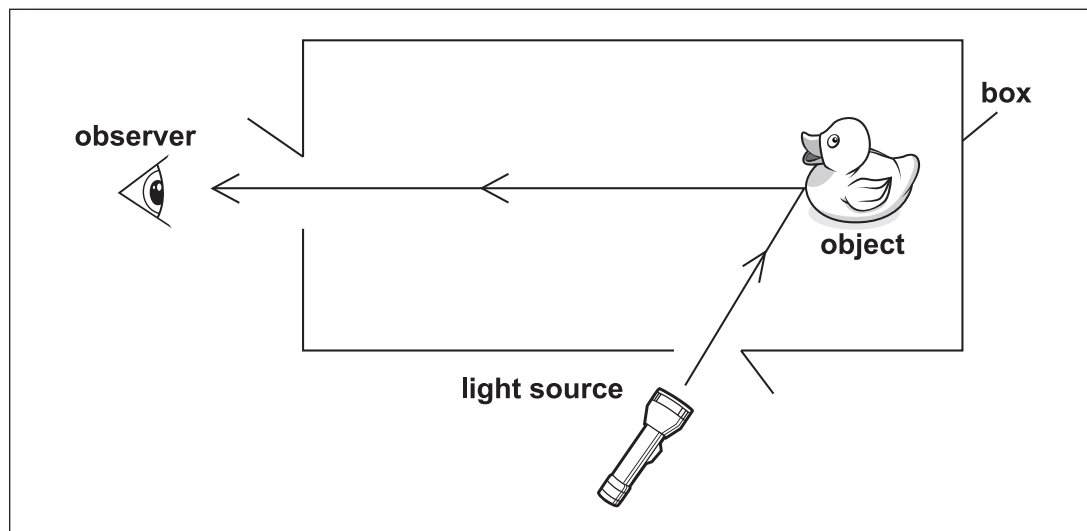
- 9 Draw the light source, box, object and eye from a bird's eye perspective on the board. Ask each team to draw their ray diagram to demonstrate how the light helped them to see the object in their peek box.



Ray diagram showing path of light in the peek box

- 10 Record students' responses on the 'How does light help us see?' section of the science chat-board.
- 11 Invite students to reflect on their learning by completing the sentence starters prepared in the class science journal:
- Today we...
  - I learned that...
  - Things I'm not sure about are...
  - Things I'm interested to find out about are...
- 12 Update the science chat-board and word wall with words and images.

## Curriculum links

### Mathematics

- Compare and discuss changes in direction and ways to represent this. For example, one student makes tracks in sand or earth and another student records. Compare how tracks look when someone changes direction and ways this can be represented.
- Explore bird's eye view.

# Session 2 The travelling light show

## Equipment

### FOR THE CLASS

- class science journal
- science chat-board
- team roles chart
- team skills chart
- word wall
- collection of photographs and pictures (eg, from books, magazines or calendars) showing sunlight shining in straight lines
- 1 strong torch or light
- 1 ruler (or shadow puppet)
- *optional*: spare batteries for torches
- *optional*: 3 large pieces of card with a hole made in each

### FOR EACH TEAM

- role wristbands or badges for Director, Manager and Speaker
- each team member's science journal
- 3 pieces of card, 10 cm x 15 cm, with a hole made in each
- 1 torch
- *optional*: 1 piece of plastic pipe (eg, garden hose) about 30 cm long

## Preparation

- If possible, organise a room that is dark or that can be darkened, and a good light source, such as a strong torch, a standing lamp, an overhead projector or a data projector.

## Lesson steps



- 1 Review the shadow activities from the previous session by asking students questions, such as:

- What helps us to see?
- What are ray diagrams?



- 2 Explain that students will be working in collaborative learning teams to investigate light and shadows. Discuss shadows by asking students questions such as:

- What is a shadow?
- How is a shadow created?
- What do you notice about the shape of the shadow?
- Why do you think shadows change during the day?
- Can we have shadows at night?

- 3 Discuss with students that light is needed to create a shadow and that light can emanate from different sources.

Compile a list of different light sources. (This could be done as a class or a collaborative learning activity.)



- 4 Display pictures or photographs showing sunlight shining in straight lines, such as through mist in the early morning or through trees in a rainforest and ask students to describe how the light is depicted.
- 5 Explain that teams will investigate how they can demonstrate that light travels in straight lines using at least three cards with a hole punched in each, or a plastic tube. For example, they will have to line up the holes or not bend the tube in order to see an object. Light will not travel through a bent tube as light travels in straight lines through the air.



- 6 Form teams and allocate roles. Ask Managers to collect team equipment.
- 7 After teams have completed their investigations, discuss teams' observations using questions, such as:



- How did you have to hold the cards to look through them and see an object?
- Why did the holes have to be in line with your eye?
- Why could we see through the holes?
- What did you see when you looked through a bent rubber tube?
- What would you have to do if you wanted to see an object through a tube?

*Optional:* Using larger pieces of card with larger holes in them, shine a bright light through the holes in three pieces of cardboard onto a wall or screen to demonstrate that the holes must be aligned for the light to be seen on the wall.

- 8 Shine a torch on a vertical ruler or shadow puppet to demonstrate the way light travels in straight lines and forms a shadow behind an opaque object that blocks the light. Ask students to note that the shadow is formed where the ruler/puppet stops the light. The shadow is behind the ruler/puppet directly in line with the light source.



- 9 Discuss students' observations with questions, such as:



- How is the shadow formed?
- How can you tell that light travels in straight lines?



- 10 Ask volunteers to draw (on the board or in the class science journal) a labelled diagram showing how a shadow is formed, using arrows to represent the light rays. Discuss the purpose and features of a labelled diagram.

### Literacy focus

#### Why do we use a labelled diagram?

We use a **labelled diagram** to show the shape, size and features of an object.

#### What does a labelled diagram include?

A **labelled diagram** might include a title, an accurate drawing, a scale to show the object's size and labels showing the main features. A line or arrow connects the label to the feature.

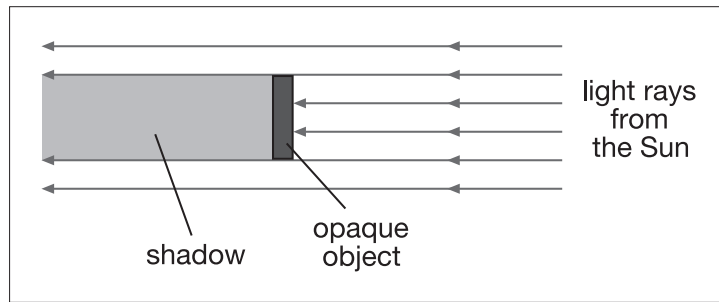

### Using a labelled diagram to represent shadow formation



- 11** Demonstrate that movement of the shadow can occur when the torch moves and also when the ruler/puppet moves. Challenge students to identify different ways in which the shadow behind the ruler/puppet could be made to move by asking questions, such as:

- What will make the shadow longer or shorter?
- What happens to the shadow when the light is above the ruler/puppet?



- 12** Ask students to draw a labelled diagram of their observations in their science journals. Provide students with time to write, draw and reflect on their learning in their science journals.

- 13** Update the word wall and the science chat-board with words and images.

# Lesson 3 Mirror, mirror

## AT A GLANCE

To provide students with hands-on, shared experiences of how light travels.

Students:

- explore how to make light travel around a corner using mirrors
- use this knowledge to devise their own challenges.

## Lesson focus

The *Explore* phase is designed to provide students with hands-on experiences of the science phenomenon. Students explore ideas, collect evidence, discuss their observations and keep records, such as science journal entries. The *Explore* phase ensures all students have a shared experience that can be discussed and explained in the *Explain* phase.

EXPLORE

## Assessment focus



**Formative assessment** is an ongoing aspect of the *Explore* phase. It involves monitoring students' developing understanding and giving feedback that extends their learning. In this lesson you will monitor students' developing understanding of:

- how mirrors can be used to reflect light in different directions.

You will also monitor their developing science inquiry skills (see page 3).

## Key lesson outcomes

### Science

Students will be able to:

- identify that light travels in straight lines
- use mirrors to reflect light in different directions
- use ray diagrams to show the reflection of light by a mirror.

### Literacy

Students will be able to:

- discuss observations of how light travels
- record ideas about light travelling
- use talk to reason about how light travels
- extend vocabulary related to light.

This lesson also provides opportunities to monitor the development of students' general capabilities (highlighted through icons, see page 5).

## Teacher background information

Light radiates from its source in straight lines. If it encounters matter, it is reflected, transmitted (let through) or absorbed (transformed into heat energy). More light reflects from smooth, shiny surfaces in an ordered way compared with light from irregular or dull surfaces, which is reflected in a more disordered way. However, all objects reflect some amount of light. Light might appear to travel on a curved path (eg. a mirage). Matter can cause the ray to change direction and a continuous change in the amount of matter can cause a continuous change of direction.

We can use these characteristics of light to manipulate it. Reflective surfaces can be used to direct light where we want it to go. A mirror is a very good reflective surface. It reflects light so well that we can see an image of an object placed in front of it. Light always reflects off a smooth surface at the same angle it strikes. Other surfaces will scatter the light in all directions because, at the microscopic level, the surface is uneven.

## Students' conceptions

Some students might believe that you can only see the image of an object in a mirror if it is directly in front of the mirror. However, an image of objects to the side of a mirror can be seen if the observer is correctly positioned.

## Equipment

### FOR THE CLASS

- class science journal
- science chat-board
- team roles chart
- team skills chart
- word wall
- self-adhesive notes
- set of mirrors and objects (see 'Preparation')
- talcum powder
- 1 torch

### FOR EACH TEAM

- role wristbands or badges for Director, Manager and Speaker
- each team member's science journal
- 1 thick book able to stand upright on a table or stack of books
- collection of objects (see 'Preparation')
- 1 mirror, 8 cm x 5 cm approximately
- 1 large sheet of butcher's paper
- 1 torch
- *optional*: an opaque blanket or similar (see 'Preparation')

## Preparation

- Collect or purchase plastic mirrors for each team (see school equipment catalogues). If these are unavailable then it might be necessary to source mirrors, for example, by asking local glass providers for off cuts with safe edges. Each team will need at least one mirror for this lesson.



Make sure that the edges of the mirrors are safe for handling. If using off cuts, tape the sides or smooth them to prevent injury.

- Collect objects with smooth surfaces that will reflect light easily, such as metal spoons, coffee cups and glossy-surfaced books.



- Prepare equipment for making dark spaces for students to work in to enable them to see their torch light. This may be a large dishwasher or refrigerator box, blankets or sheets for covering desks or a large table in a corner covered with thick blankets that touch the floor. Darkening the classroom will also help.

**Note:** In order to be able to clearly see the light travel, it is best to have a torch with a strong, focused beam.

- Prepare the following questions in the class science journal for students to use when reflecting on their learning in this lesson (see Lesson step 12):
  - How did the light travel?
  - How were you able to make the light go around a corner?
  - What other objects were able to reflect light like a mirror?

## Lesson steps



- 1 Review the 'Shining light' lesson (Lesson 2 Session 1) by asking questions, such as:
  - Why could we not see the object in the box originally? (There was no light to reflect from the object to our eyes.)
  - What did we need to do so that we could see the object in the box? (Let some light in to shine on the object and reflect to our eyes.)
  - What was the best position for the torch to be in for us to be able to see the object clearly? (Close to the opening and shining on the side of the object that our eyes were looking at.)



- 2 Ask students to predict where the light from a torch will go when you switch it on. Point it in a different direction and ask again. Ask them how they know where it will go. (Because light travels in a straight line.)



- 3 Select a student to help demonstrate how we can see where the light travels from the torch. Ask the student to sprinkle talcum powder in front of the torch. Ask the students about what they see and what they think is happening. (The talcum powder particles get in the way of the light. You don't actually see the beam of light, you see the particles that are in the path of the light because the light reflects off the talcum powder particles into your eyes.)



- Remind students to be a safe distance away from the talcum powder to avoid inhaling it.
- 4 Shine the torch onto the floor or a student's foot. Ask a student to draw a ray diagram in the class science journal showing the path the light has taken from the torch to the floor and from the floor to the eye.
  - 5 Explain that students will be working in collaborative learning teams to investigate how light travels. Challenge teams by asking how they can make light go around a pile of books. Ask each team to put a sheet of paper on the desk, lie the torch on the sheet of paper and draw the path of the light from the torch to the observer's eye to complete a ray diagram.

**Note:** Have mirrors available in readiness.

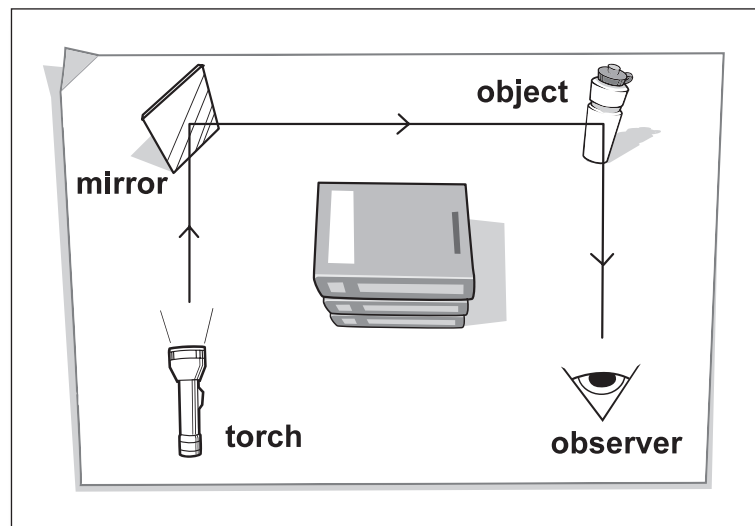

Example of equipment set up



SAFETY

Light could damage the eye if shone directly or reflected from a very shiny surface into the eye. Encourage students to view light reflecting from a dull surface or object.



- 6 Form teams and allocate roles. Ask Managers to collect team equipment. Allow time for students to explore a variety of light beam pathways.



- 7 Discuss with the class why a mirror was needed to make the light go around the corner (light travels in straight lines and mirrors are good light reflectors) and to suggest other things that also reflect lots of light, such as cutlery, still water, car windscreens and polished floors.

**Note:** Objects that have smooth surfaces, for example, mirrors, reflect most light in a regular pattern and are good light reflectors. Objects that have irregular surfaces, for example, soft toys, scatter light in all directions and are not good light reflectors.

- 8 Invite each Speaker to share their team's ray diagrams with the class.



- 9 Allow teams time to explore with the torch and mirrors and develop their own challenges, for example, using four mirrors to try to send the light beam to a different position.



- 10 Suggest that teams try using different objects to reflect the light. Ask teams to predict what will happen when they use the different objects, and to record their predictions and results in their science journals.



- 11 Organise the class so that each group can describe one challenge that their team set up and explain their results.



- 12 Allow time for students to discuss their observations and record them on the prepared page in the class science journal. Ask questions, such as:

- How did the light travel?
- How were you able to make the light go around a corner?
- What other objects were able to reflect light like a mirror?

Record students' responses on the 'How does light travel?' section of the science chat-board.

- 13 Update the science chat-board and word wall with words and images.

## Curriculum links

### English

- Read fables about reflected images, for example, 'The dog and his reflection' by Aesop.

### Mathematics

- Explore symmetry with mirrors.

### Studies of Society and Environment

- Explore the history and manufacture of mirrors, including the use of mirrors in signalling messages and how Morse code is used as a means of communication.

# Lesson 4 Make way for the light

## AT A GLANCE

To provide students with hands-on shared experiences of how different materials (transparent, translucent or opaque) affect the transmission of light.

Students:

- explore how the path of light is affected by different materials
- sort materials into transparent, translucent and opaque categories.

## Lesson focus

The *Explore* phase is designed to provide students with hands-on experiences of the science phenomenon. Students explore ideas, collect evidence, discuss their observations and keep records, such as science journal entries. The *Explore* phase ensures all students have a shared experience that can be discussed and explained in the *Explain* phase.

## Assessment focus



**Formative assessment** is an ongoing aspect of the *Explore* phase. It involves monitoring students' developing understanding and giving feedback that extends their learning. In this lesson you will monitor students' developing understanding of:

- the effect of various materials on the transmission and absorption of light.

You will also monitor their developing science inquiry skills (see page 3).

## Key lesson outcomes

### Science

Students will be able to:

- explore materials and how they affect light
- sort materials according to their ability to affect the path of light
- explain that light can be transmitted by a range of materials
- discuss the use of different materials for transmitting light
- sort materials into transparent, translucent and opaque categories.

### Literacy

Students will be able to:

- describe the amount of light passing through materials according to what can be seen through the material
- discuss observations of how light is affected by different materials
- use a table to sort and record information
- use talk to provide reasons for classifying materials into transparent, translucent and opaque categories.

This lesson also provides opportunities to monitor the development of students' general capabilities (highlighted through icons, see page 5).

## Teacher background information

We see objects when they reflect light into our eyes. There are different ways for objects to interact with light, depending on the composition of their materials and the regularity of their surfaces.

Transparent, translucent and opaque surfaces all reflect some light otherwise we could not see them. However, they reflect light in differing ways and amounts.

- Transparent materials, such as glass or water, transmit (let through) most light without it being scattered or absorbed. They still reflect some light otherwise we could not see them. Very clear glass might appear to be invisible because virtually all light is transmitted. Because most light is transmitted through transparent materials, we can see objects through them.
- Translucent materials, such as wax paper and frosted glass, transmit less light than transparent materials. Some light is scattered or absorbed and some is reflected. We can see objects through translucent materials but because some of the light is scattered or absorbed we cannot see them clearly.
- Opaque materials, such as cardboard or wood, scatter, absorb or reflect most light and transmit almost no light. Thus, we cannot see through them. The light which is reflected does so in a scattered way, that is, in all directions. Depending on the composition, opaque materials absorb some colours of visible light more than others. The material will appear the colour that it reflects the best.

Imagine a room containing objects and surfaces of different types. Light radiation emerges from its source in all directions in straight lines. The materials transmit, reflect and absorb the light in different amounts and in different ways, producing different effects. For example, a white room with shiny surfaces has light reflecting from surface to surface, filling the room

with light. By contrast, a dark-coloured room with coloured, dull surfaces absorbs more light than it reflects, creating a darker effect.

**Note:** Students might know a range of meanings for the word ‘material’, such as fabric or written information. For this unit, the term ‘material’ refers to what an object is made of, such as glass, plastic or paper.

## Equipment

### FOR THE CLASS

- class science journal
- science chat-board
- team roles chart
- team skills chart
- word wall
- 1 enlarged copy of ‘Passing through?’ (Resource sheet 3)
- 1 enlarged copy of ‘I can see the light’ (Resource sheet 4)
- samples of materials (see ‘Preparation’)
- 1 torch

### FOR EACH TEAM

- role wristbands or badges for Director, Manager and Speaker
- each team member’s science journal
- 1 copy of ‘Passing through?’ (Resource sheet 3) per team member
- 1 copy of ‘I can see the light’ (Resource sheet 4) per team member
- samples of materials (see ‘Preparation’)
- self-adhesive tape
- 1 torch

## Preparation

- Collect samples of materials for each team that demonstrate degrees of transparency from transparent through translucent to opaque, such as clear plastic, baking paper or tissue paper, plain white A4 paper, cardboard, bubble wrap and foil.

**Note:** Do not use fabrics. This will confuse students as light will pass through the spaces between the threads.

- Prepare an enlarged copy of ‘Passing through?’ (Resource sheet 3) and ‘I can see the light’ (Resource sheet 4).
- *Optional:* Display ‘Passing through?’ (Resource sheet 3) and ‘I can see the light’ (Resource sheet 4) on an interactive whiteboard or a computer connected to a projector. Check the PrimaryConnections website to see if an accompanying interactive resource has been developed ([www.primaryconnections.org.au](http://www.primaryconnections.org.au)).

## Lesson steps



- 1 Review the previous lesson by asking questions, such as:
  - In what directions did the light travel? (From the torch, to the object, to the eye.)
  - What was the purpose of the mirror? (To make the light change direction.)
  - What other good light reflectors might you be able to use if you did not have a mirror?



- 2 To introduce the topic, ask questions, such as:
- What would happen if you put something in the way of the light?
  - Can you think of some materials that let light through?
  - Can you think of some materials that don't let light through?

**Note:** The term 'material' in this unit refers to the substance of which an object is made rather than fabric.

Record students' ideas and predictions on the science chat-board in the 'How does light travel?' section.

- 3 Explain that students will be working in collaborative learning teams to investigate the amount of light that different materials allow to pass through.
- 4 Model the process of exploring the materials:
- Choose a material or object and place over the end of the torch.
  - Switch on the torch.
  - Observe the amount of light that comes through onto a white wall or screen.
  - Introduce the enlarged copy of 'Passing through?' (Resource sheet 3) and record the name of the material.
  - Discuss what a continuum is and put a cross on the line to show how much light passes through the modelled material.

Remind students not to shine the torch directly into their eyes.

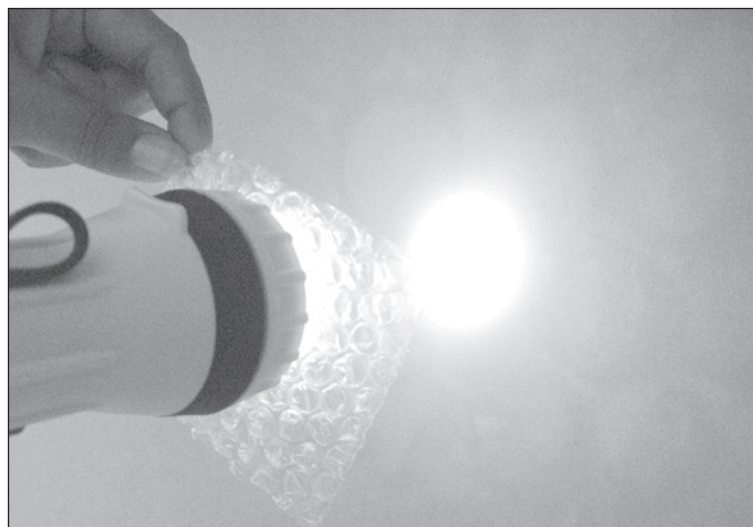

**Photo of a material over torch**

**Note:** When modelling, select materials that will not be used by students in their investigation, such as paper towel, cling wrap, plastic from a transparent plastic bag or a clipboard.



- 5 Form teams and allocate roles. Ask Managers to collect team equipment.

- 6** After the exploration, invite Speakers to share their team's results with the class. Ask questions, such as:
- Which materials allowed the light to pass through?
  - Did you find any materials that let some light through?
  - Which materials didn't let the light through?
  - Can you put your objects in order from 'Doesn't let light through' to 'Lets lots of light through'?
  - Which materials made the best shadows?
  - How is a shadow made?
- 7** Ask volunteer students to construct ray diagrams on the board to show how transparent, translucent and opaque materials can block light. Discuss the representations, encouraging students to describe and justify their diagrams.

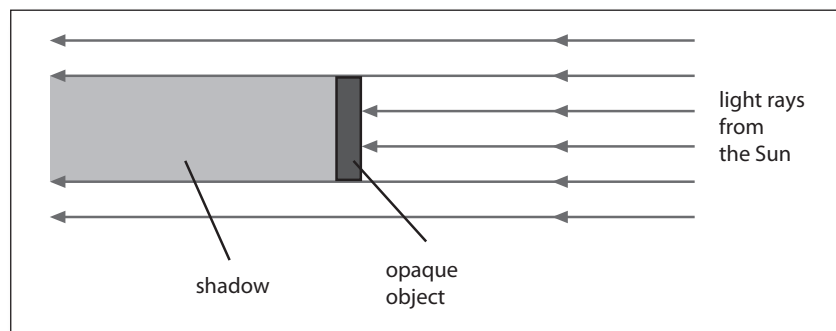

**Diagram of shadow formation**

- 8** Introduce the enlarged copy of 'I can see the light' (Resource sheet 4). Discuss the words 'transparent', 'translucent' and 'opaque' and their descriptions. Add the words to the word wall section of the science chat-board.
- 9** Explain to students that they will use their results from 'Passing through?' (Resource sheet 3) to sort the materials into the three categories of transparent, translucent and opaque. Encourage students to use the equipment to confirm their answers.
- 10** Re-form teams. Ask Managers to collect team equipment.
- 11** After the exploration, invite Speakers to share their team's results with the class. Record results in the class science journal. Ask questions, such as:
- Which materials were transparent?
  - Which materials were translucent?
  - Which materials were opaque?
  - When or where would you use transparent, translucent or opaque materials?
- 12** Discuss with students what they think happens to the light that passes through the materials. How far does it travel? Ask students to think about the light from the Sun and stars. Even though they are far away, the light still travels so we can see it. Discuss with students how light will continue to travel until something gets in its way, such as a wall, a hand or smoke.



- 13** Update the science chat-board and word wall with words and images.

*Optional:* A whole class continuum could be created starting at 'Doesn't let light through' and ending with 'Lets lots of light through'. Encourage students to represent their findings in various forms, such as diagrams, pictures, digital images and magazine images which are then placed along the continuum.

## Curriculum links

### English

- Develop descriptive and comparative language to distinguish between transparent, translucent and opaque materials.

























### Health and Physical Education

- Explore different types of sunglasses to determine which styles are most effective.
- Brainstorm types of window coverings to have in a baby's room to help the baby sleep during the day.

# Passing through?

Name: \_\_\_\_\_ Date: \_\_\_\_\_

Put a cross on the line to show how much light goes through the material or object.

Material or object	Lets lots of light through 	Lets some light through 	Doesn't let light through 
			
			
			
			
			
			
			

# I can see the light

Name: \_\_\_\_\_ Date: \_\_\_\_\_

Look at your resource sheet, 'Passing through?'. Decide which materials are transparent, translucent or opaque. Write or draw the objects or materials in the matching section below.

**Transparent** materials let light through. Objects can be seen clearly through transparent materials.

**Translucent** materials let some light through. Objects cannot be seen clearly through translucent materials.

**Opaque** materials don't let light through. Objects cannot be seen through opaque materials.

# Lesson 5 Light illusions

## AT A GLANCE

To provide students with hands-on shared experiences of how water refracts light.

Students:

- explore the apparent distortion of objects when viewed through water
- work in teams to investigate light passing through a glass of water
- make claims about why objects appear distorted in water.

## Lesson focus

The *Explore* phase is designed to provide students with hands-on experiences of the science phenomenon. Students explore ideas, collect evidence, discuss their observations and keep records, such as science journal entries. The *Explore* phase ensures all students have a shared experience that can be discussed and explained in the *Explain* phase.

## Assessment focus



**Formative assessment** is an ongoing aspect of the *Explore* phase. It involves monitoring students' developing understanding and giving feedback that extends their learning. In this lesson you will monitor students' developing understanding of:

- refraction and its effect on the appearance of objects when viewed through water.

You will also monitor their developing science inquiry skills (see page 3).

## Key lesson outcomes

### Science

Students will be able to:

- explore transparent materials and how they affect the direction of light rays
- discuss and describe observations about refraction
- discuss uses of refraction and how light can be magnified through different objects
- test predictions by using evidence to develop explanations of illusions created by the refraction of light
- reflect on the investigation suggesting new variables to test.

### Literacy

Students will be able to:

- understand the purpose and features of a procedural text
- follow a procedural text to conduct an investigation
- discuss and compare results to form common understandings.

This lesson also provides opportunities to monitor the development of students' general capabilities (highlighted through icons, see page 5).

## Teacher background information

Transparent materials, such as air, water and glass, enable light to transmit through them to see objects beyond them. Sometimes objects appear distorted when viewed through transparent materials, for example, a straw in a glass of water. When light is transmitted through two transparent materials, such as air and water, it can be bent where the two surfaces meet in a process called refraction. This is called refraction. In the wave model, refraction occurs because the wave travels at different speeds in the two transparent materials.

During this lesson, students investigate the direct effect that water has on light by directing a thin beam of light through a glass of water. Light will pass through the centre of a clear plastic cup of water with little refraction, but when it contacts the curved surface on either side of the cup, the light is refracted at an angle. Light travels slower through water than air. When light contacts the surface of the water in the cup it slows down, causing the beam of light to travel at a different angle. When the light leaves the water and travels back through the air it changes speed again, causing the light to bend at yet another angle.

The convex shape of the water in the cup can help magnify objects by refracting the light reflected by an object before it meets your eyes. An object might appear to disappear if it is positioned behind the curved edge of the cup because the light reflected by the object is bent in another direction and does not meet your eyes.

Refraction has some important uses, for example, in eye glasses to correct focus so objects don't appear blurred. The convex shape of the magnifying glass refracts the light so that an object appears larger than if it were to be viewed through air alone.

## Students' conceptions

Some students might believe that light always travels in the same direction, in a straight line. This is so if the light is travelling through a uniform medium. When light travels from one medium to another it could be reflected, absorbed or refracted at the boundary between these two media, in which case it moves in a straight line, in a different direction, or is absorbed in the material and converted to heat energy. Some media are so similar in properties that the light continues to travel very close to a straight line. Light is bent by refraction when it enters the glass of a window, but is bent back to its original direction when it emerges again into the air, so that the window glass is nearly invisible.

## Equipment

### FOR THE CLASS

- class science journal
- science chat-board
- team roles chart
- team skills chart
- word wall
- 1 enlarged copy of 'Line of light investigation planner' (Resource sheet 5)
- 1 enlarged copy of 'Exposing the illusion' (Resource sheet 6)
- self-adhesive notes

### FOR EACH TEAM

- each team member's science journal
- 1 copy of 'Line of light investigation planner' (Resource sheet 5) per team member
- 1 copy of 'Exposing the illusion' (Resource sheet 6) per team member
- card, 20 cm x 20 cm
- pencil
- round clear plastic cup
- torch
- water
- ruler
- scissors

## Preparation

- Collect enough round clear plastic cups for each team.

**Note:** Avoid cups that have a thick or raised patterned base because they will refract the light through the base and might not show any difference when water is added. These containers could be used for further investigations.



- Ensure safety when handling glass containers.
- Prepare an enlarged copy of 'Line of light investigation planner' (Resource sheet 5) and 'Exposing the illusion' (Resource sheet 6).
- *Optional:* Display the 'Line of light investigation planner' (Resource sheet 5) and the 'Line of light inquiry overview' (Resource sheet 6) on an interactive whiteboard or on a computer connected to a projector. Check the PrimaryConnections website to see if an accompanying interactive resource has been developed ([www.primaryconnections.org.au](http://www.primaryconnections.org.au)).

## Lesson steps



- 1 Review previous lessons by asking questions, such as:
  - What do you know about transparent materials?
  - Are you always able to see clearly through the materials? Why/why not?
 Record students' answers in the class science journal.
- 2 Explain that students will be working in collaborative learning teams to observe what happens to a pencil when they view it through an empty clear plastic cup and then what they observe when they fill the cup  $\frac{3}{4}$  full with water. Ask teams to make their observations looking through the side part of the clear plastic cup. Encourage students to move the pencil from side to side behind the clear plastic cup.
- 3 Ask students to record their observations as a labelled diagram in their science journals.

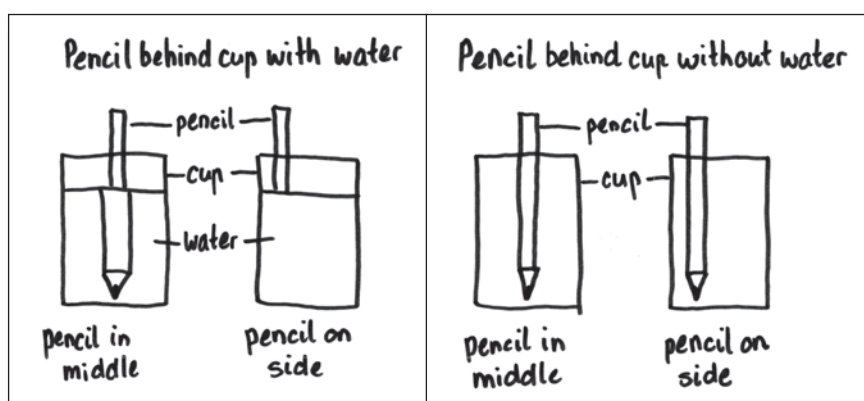

Work sample of pencil and cup observations



- 4 Form teams and allocate roles. Ask Managers to collect team equipment. Allow time for teams to complete observations.



- 5 Ask students to report their observations, asking questions, such as:
  - What did you observe before water was added?
  - What did you observe after water was added?
  - What happened when you viewed the pencil directly behind the container? (It was magnified.)
  - Can you think of some other objects that magnify? (Eye glasses, magnifying glass, telescope.)
  - What happened when you viewed the pencil through the curved edge of the container? (It disappeared.)
  - Why do you think that happened?

Record students' observations in the class science journal.



- 6 Using the class science chat-board section 'How light helps us see', ask students what they have found out about light, such as light travels in straight lines, we see an object when light hits an object and then it reaches our eyes.



- 7 Discuss with students that if light helps us to see objects then what is happening to the light rays in the water before they reach our eyes to make the bottom of the pencil disappear?

- 8 Explain that students will work in collaborative learning teams to answer the question for investigation ‘What happens to a beam of light when it passes through a glass of water?’
- 9 Introduce the enlarged copy of ‘Line of light investigation planner’ (Resource sheet 5) and discuss the features and purpose of procedural texts.





### Literacy focus

#### Why do we use a procedural text?

We use a **procedural text** to find out how something is done. We can read a **procedural text** to find out how to do things.

#### What does a procedural text include?

A **procedural text** includes a list of materials needed to do the task and a description of the sequence of steps used. It might include annotated diagrams.

- 10 Read through the ‘Line of light investigation planner’ (Resource sheet 5) with students and model how to complete each step.
-  11 Ask students to predict what they think will happen to light as it passes through water and provide reasons for their prediction. Ask teams to record their prediction.
-  12 Form teams and allocate roles. Ask Managers to collect the equipment.  
Allow teams time to complete their investigation of light refraction through clear round containers and water.
-  13 Ask Speakers to share their team’s results. Use the ‘Science question starters’ (see Appendix 4) to encourage dialogue between students. Ask students if their results matched their predictions and discuss.
- 14 Record a summary of the class results in the ‘Explaining results’ section of the enlarged copy of ‘Line of light investigation planner’ (Resource sheet 5), for example, ‘A beam of light bends when it enters the cup with water but not when there is only air’.
- 15 Introduce the enlarged copy of ‘Exposing the illusion’ (Resource sheet 6). Read through the three claims. Explain that these are three possible claims to answer the original inquiry question, ‘What happens to a beam of light when it passes through a glass of water?’
-  16 Ask students to discuss and choose which claim they think they can make based on their evidence. Record the agreed claim in the class science journal.
- 17 Update the science chat-board and word wall with words and images.

## Curriculum links

### Science

- Observe and compare refraction using cups of oil, water and a mixture of oil and water.



# Line of light investigation planner

Name: \_\_\_\_\_ Date: \_\_\_\_\_

**Question** What do we want to find out?

**Prediction** What do we think will happen?

## What do we need?

- each team member's science journal
- clear plastic cup
- pencil
- piece of card (20 cm x 20 cm)
- water
- ruler
- torch
- scissors

## What will we do?

1. Find a dark place and a flat surface to work on.
2. Use a ruler and pencil to rule a line on the card that is 10 cm high and about 1 mm thick. Use scissors to cut along the line to create a slot.
3. Hold the card upright and place the torch behind the card so that a thin light beam shines through the slot.
4. Place the centre of the empty cup in the path of the light beam and observe what happens to the light beam.
5. Move the cup from side to side, observing what happens to the light beam each time you move the cup.
6. Fill the cup  $\frac{3}{4}$  full with water and repeat steps 4–6.

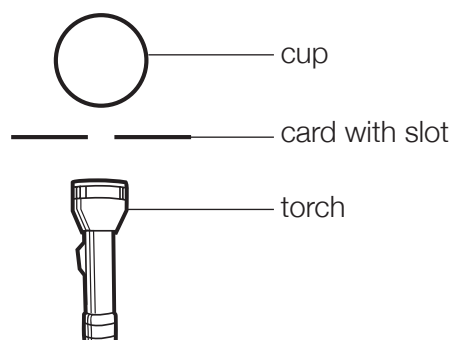

**Bird's-eye view of investigation set-up**

# Line of light investigation planner

**Recording results** Draw a labelled diagram to show what happened

**Bird's-eye view of the beam of light  
encountering the cup without water**

**Bird's-eye view of the beam of light  
encountering the cup with water**

**Explaining results** What happened to the beam of light? Why do you think that happened?

# Exposing the illusion

Using what you have learned from your investigation, match the side view of the pencil behind the glass to the description and diagram that best explains what happens to the ray of light to give the illusion of a disappearing pencil.

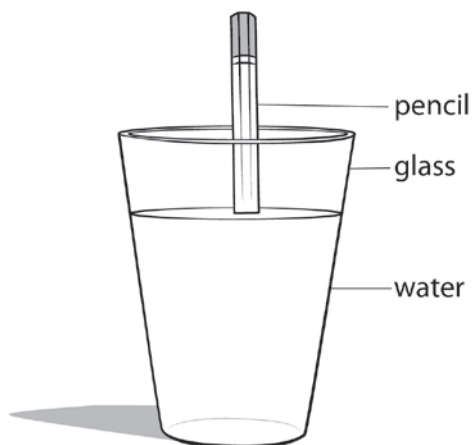

The bottom of the pencil looks like it disappears because:

The light is reflected by the glass and does not reach my eyes.

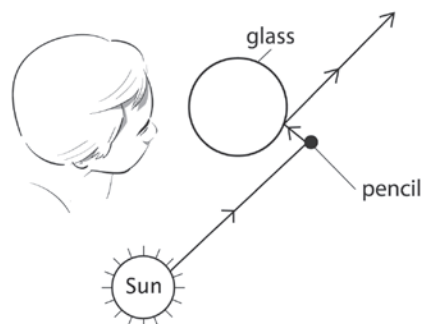

The light reflected by the pencil bends when it goes from air to water and does not reach my eyes.

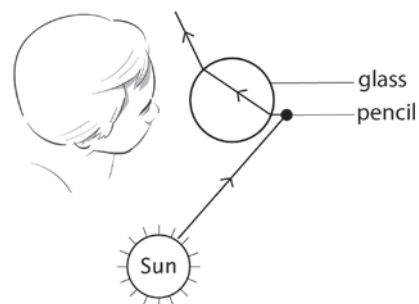

The light reflected by the pencil gets trapped inside the glass and does not reach my eyes.

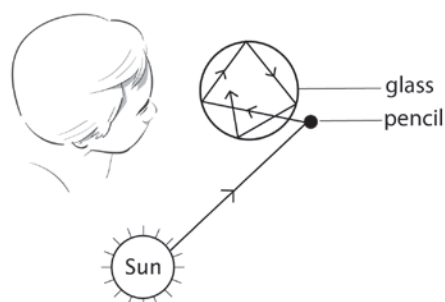

# Lesson 6 Sneaky spy

## AT A GLANCE

To support students to represent and explain their understanding of how light from a source forms shadows and can be absorbed, reflected and refracted, and to introduce current scientific views.

Students:

- construct a periscope to demonstrate light travelling in straight lines and being reflected
- record and represent their understanding of light using a ray diagram and a written description.

## Lesson focus

In the *Explain* phase students develop a literacy product to represent their developing understanding. They discuss and identify patterns and relationships within their observations. Students consider the current views of scientists and deepen their own understanding.

## Assessment focus



**Formative assessment** is an ongoing aspect of the *Explain* phase. It involves monitoring students' developing understanding and giving feedback that extends their learning. In this lesson you will monitor students' developing understanding of:

- that light enables us to see and travels in straight lines until it encounter objects that might reflect, refract or absorb it.

You will also monitor their developing science inquiry skills (see page 3).

## Key lesson outcomes

### Science

Students will be able to:

- identify sources of light
- explain that light travels in straight lines
- draw a ray diagram to explain how light from a source is reflected off an object into our eyes
- construct a periscope to see an object around a corner.

### Literacy

Students will be able to:

- represent the path of a light beam using a ray diagram
- use scientific vocabulary when explaining how light travels.

This lesson also provides opportunities to monitor the development of students' general capabilities (highlighted through icons, see page 5).

## Teacher background information

To represent the path of light, scientists use 'rays'. Rays are arrows that show the direction that light travels. A 'ray diagram' uses the drawing of rays to explain light behaviour, such as the path which light takes from a light source to our eyes, the way light is blocked by opaque objects, reflected from objects, transmitted through transparent objects, and 'bent' (or refracted) when light passes from one material to another, for example, from air into water. Light rays can travel indefinitely in a straight line if they are not absorbed, reflected or refracted.

### Students' conceptions

Many students will draw small lines emerging from a light source, such as a torch or the Sun. These lines are usually short, straight and in all directions.

Light does travel in approximately straight lines but does not stop a short distance from the source unless interrupted by matter. Depending on the nature of the source, the light might travel in multiple directions or it might be focused.

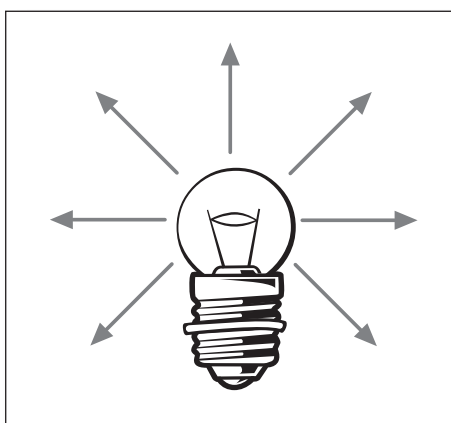

Diagram of light rays

## Equipment

### FOR THE CLASS

- class science journal
- science chat-board
- team roles chart
- team skills chart
- word wall
- 1 sample periscope made using 'Periscope pieces' (Resource sheet 7, parts 1 and 2)
- 1 enlarged copy of 'Periscope pal' (Resource sheet 8)
- self-adhesive notes

### FOR EACH TEAM

- role wristbands or badges for Director, Manager and Speaker
- each team member's science journal
- 1 copy of 'Periscope pieces' (Resource sheet 7, parts 1 and 2) per team member
- 1 copy of 'Periscope pal' (Resource sheet 8) per team member
- cardboard (eg, A4 sheets or cereal boxes)
- glue
- 1 mirror, 8 cm x 5 cm approximately, per team member
- scissors
- self-adhesive tape

## Preparation

- Prepare an enlarged copy of 'Periscope pal' (Resource sheet 8).
- Use 'Periscope pieces' (Resource sheet 7) to prepare a sample periscope.

**Note:** This activity can be completed using 1 L milk cartons instead. Wash cartons thoroughly and cut the pointy end off. Cut a 5 cm x 4 cm viewing hole on the front of the carton, 1 cm up from the base. On the opposite side of the carton to the viewing hole, measure 5 cm from the corner and mark. Measure 5 cm from the corner along the base and make another mark. Draw a line between each point to represent a 45° angle and cut the carton along this line. Attach mirror to this corner with the reflective side facing the viewing hole.

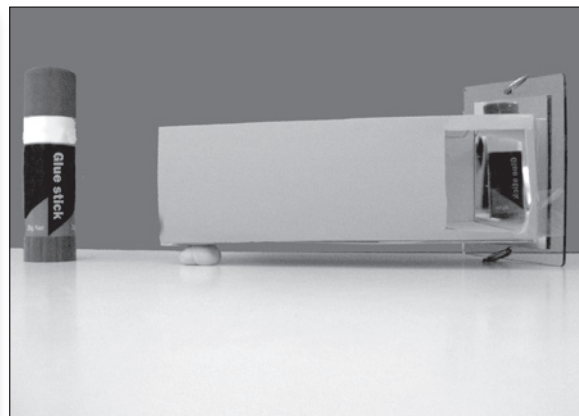
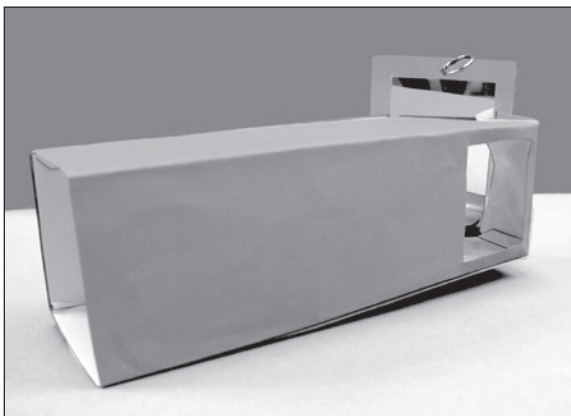

Sample periscope

## Lesson steps



1 Review previous lessons by asking questions, such as:

- Where does light come from?
- What is light used for?
- How does light travel?
- How does light help us to see?
- How is light affected by different materials?

2 Review the questions and contributions that have been made to the science chat-board.



3 Ask students to brainstorm how it would be possible to see around a corner of a building. Ask students if they know what a periscope is, how it is used and how it works. Explain how periscopes can be used to see over and around objects, for example, in submarines to see ships on the surface of the ocean.

4 Explain that students will be working in collaborative learning teams to construct a periscope and then explain how it works. To make the periscope the students will:

- cut around the template on Part 1 and Part 2 of 'Periscope pieces' (Resource sheet 7)
- trace or glue the templates onto cardboard and cut out
- cut on lines to make viewing hole
- fold the card backwards on the dashed lines to form flaps
- glue the flaps together by matching the letters
- using self-adhesive tape, attach the mirror to the sloped opening of the periscope with the reflective side inwards.

**Note:** Remind students not to discard instructions from Part 1 'Periscope pieces' (Resource sheet 7).



5 Form teams and allocate roles. Ask Managers to collect team equipment. Allow time for students to construct and test their periscopes.

6 Introduce an enlarged copy of 'Periscope pal' (Resource sheet 8) and discuss that the diagram is a 'bird's eye view' which includes a mixture of perspectives.

7 Explain that students will draw a ray diagram to show how we can see the dog around the corner of the building using the periscope. Each student will then write an explanation of the process using the scientific vocabulary on the resource sheet. Allow time for students to individually complete the resource sheet.



8 Allow time for teams to discuss their answers with team members. For students who have retained non-scientific ideas, ask questions, such as:

- Could you tell me more about that?
- What do you mean by that?
- Tell me more about your description of the path travelled by the light.
- Scientists have found that ... How does that idea fit with your idea?



9 When teams are ready, ask them to report back to the class. Compare ray diagrams and explanations. Check understanding and challenge and explain where necessary.

10 Update the science chat-board and word wall with words and images.

## Curriculum links

### English

- Create a jumbled sequence of instructions to make the periscope and ask students to place them in the right order.

### Technology

- Construct a periscope using two mirrors.

### Studies of Society and Environment

- Find out about the history of the periscope, including who invented it.



# Periscope pieces (Part 1)

## Instructions

- Cut around template on the continuous line
- Trace or glue the templates on to cardboard and cut out
- Cut on continuous line around shaded box to create viewing hole
- Fold the card on the dashed lines to form flaps
- Glue the flaps together by matching the letters
- Attach the mirror to the sloped opening of the periscope with self-adhesive tape

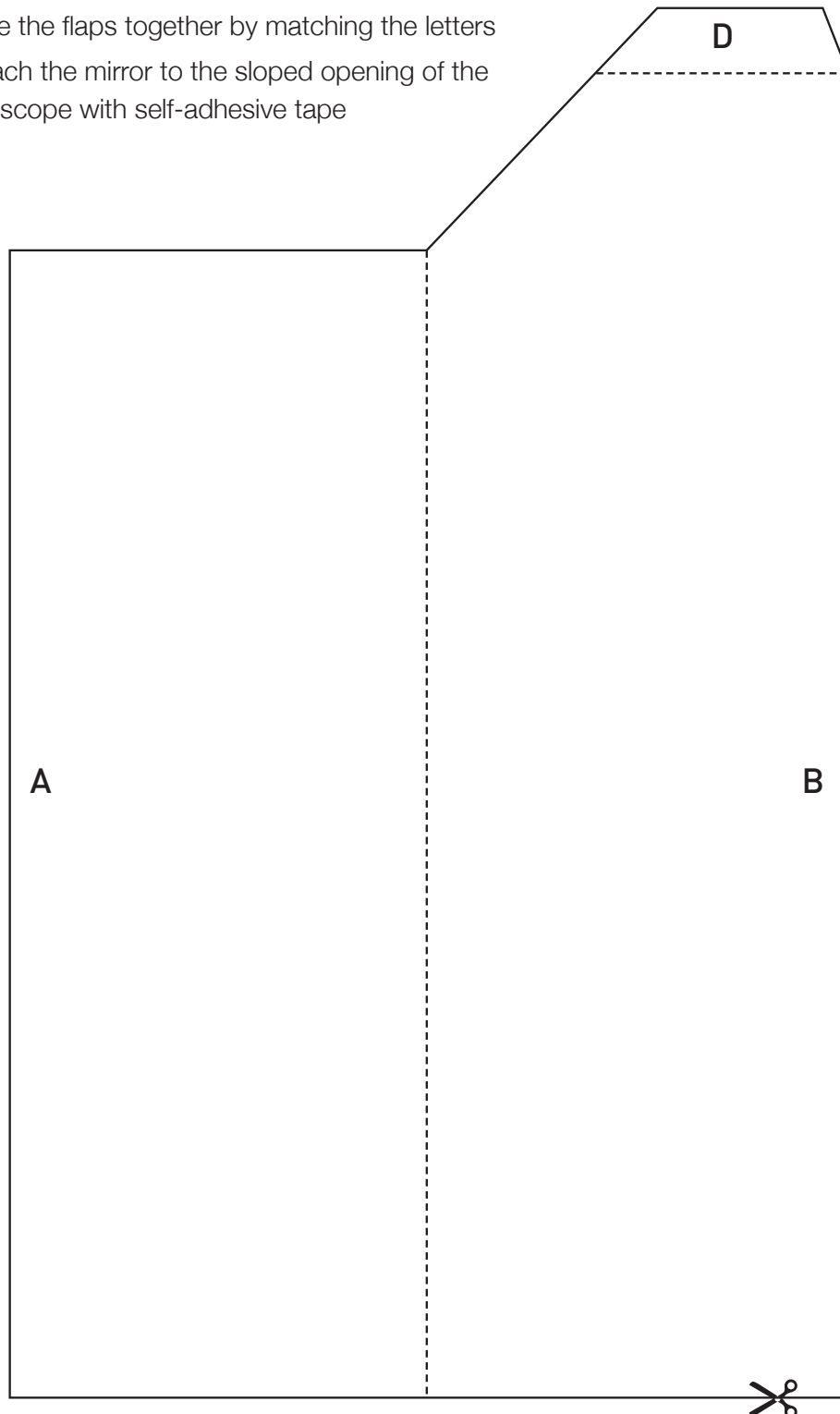

# Periscope pieces (Part 2)

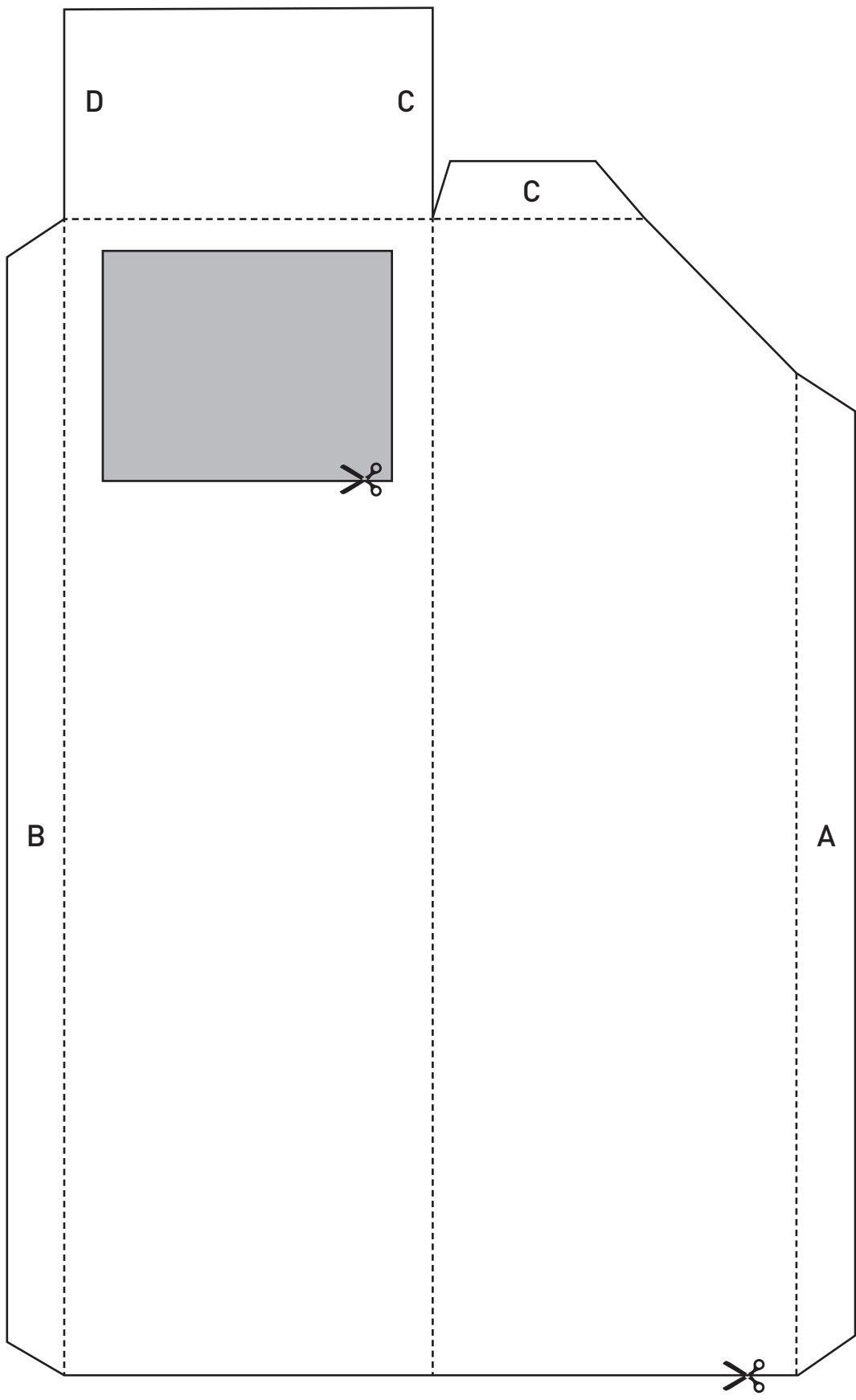

# Periscope pal

Name: \_\_\_\_\_ Date: \_\_\_\_\_

## How can you see the dog around the corner of the building?

1. Draw a ray diagram to show how light travels in the periscope and helps you to see the dog around the corner.

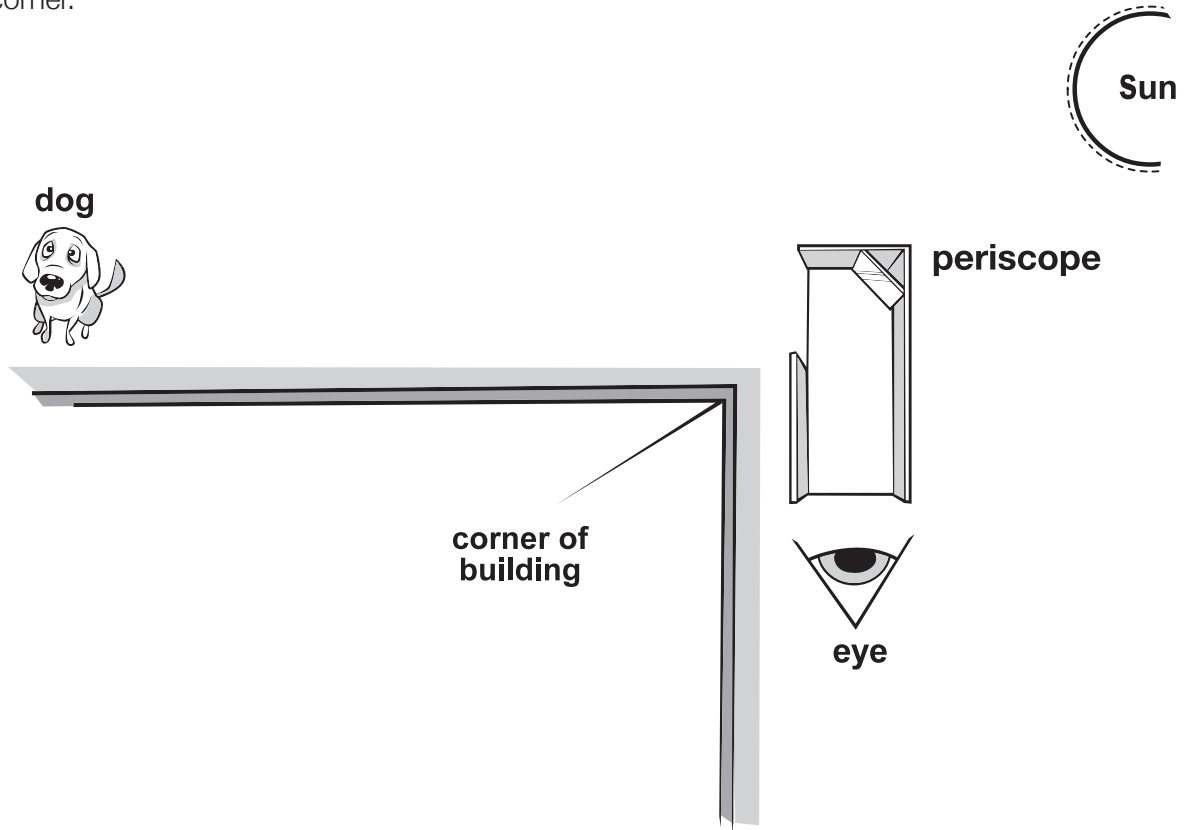

2. Explain how the periscope works using these words: light, travels, reflect, mirror, eyes, straight line, light source.

---

---

---

---

---

---

---

---

# Lesson 7 Big shadow, little shadow

## AT A GLANCE

To support students to plan and conduct an investigation of the height of shadows.

Students:

- work in teams to plan and set up an investigation of the height of shadows
- measure the height of a shadow as the distance from the torch to the object changes
- observe, record and interpret results
- explain how a shadow is formed as a result of light travelling in straight lines.

## Lesson focus

In the *Elaborate* phase students plan and conduct an open investigation to apply and extend their new conceptual understanding in a new context. It is designed to challenge and extend students' science understanding and science inquiry skills.

## Assessment focus



**Summative assessment** of the Science Inquiry Skills is an important focus of the *Elaborate* phase (see page 3).

## Key lesson outcomes

### Science

Students will be able to:

- conduct an investigation of the height of shadows showing awareness of a need for fair testing
- explain how the height of a shadow can change by changing the distance from a light source to an object
- identify variables affecting the height of shadows.

### Literacy

Students will be able to:

- participate in discussions about variables that affect shadows
- record findings in a table
- identify the purpose and features of a graph
- use a graph to represent findings.

This lesson also provides opportunities to monitor the development of students' general capabilities (highlighted through icons, see page 5).

## Teacher background information

Shadows occur when the path of light is blocked by an object. A shadow is formed on the opposite side of the object from the light source. The object, shadow and light source are in line with each other because light travels in approximately a straight line. The closer the object is to the light source the larger the shadow. This is because it blocks out more of the light. If the object is further away from the light source it will block less of the light. This will produce a smaller shadow.

If the light is coming from a broad source, for example, a torch, there will be two regions in the shadow called the 'umbra' and 'penumbra'. The umbra is the region of the shadow (the darker part) where all of the light is blocked by the object. The penumbra (the lighter part) is the region of the shadow where only some of the light is blocked, that is, the light from only part of the source is blocked out. Because light is a wave motion, it is affected by sharp edges and, as a result, some light energy appears in the umbra.

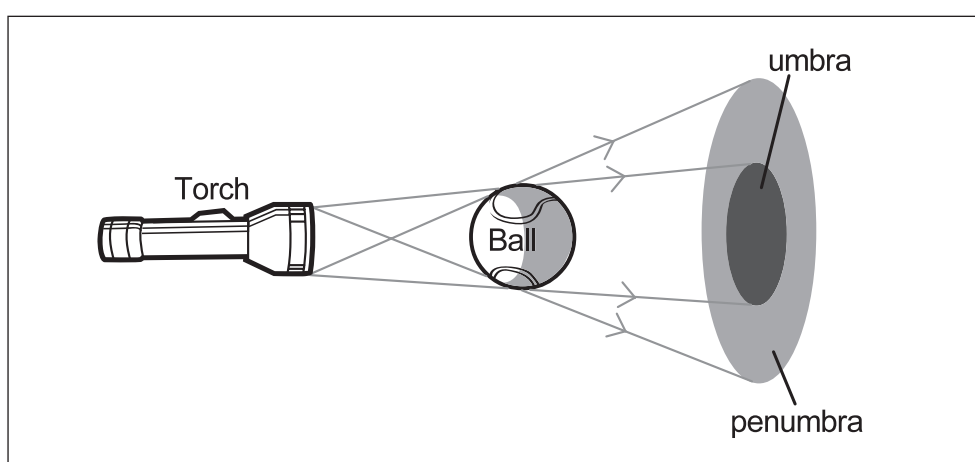

Diagram of umbra and penumbra

### Students' conceptions

Students might have non-scientific ideas about shadows. They might think that shadows exist independently of an object rather than being directly connected to an object. Some students consider them to be copies of the object rather than silhouettes. Others confuse shadows with reflections, which occur when light bounces off a surface into our eyes, allowing us to see an image. Shadows are caused by an object blocking the transmission of light. They can only be seen if light is prevented from reaching an object or surface. Their size and shape depend on the position of the light source, the properties of the object itself and the distance to the surface from which the light is blocked.

## Equipment

### FOR THE CLASS

- class science journal
- science chat-board
- team roles chart
- team skills chart
- word wall
- 1 enlarged copy of 'Shadow height investigation planner' (Resource sheet 9)
- 1 copy of 'Measurement screen' (Resource sheet 10)
- 1 x 35 g glue stick
- 1 pencil
- 1 x 30 cm ruler
- self-adhesive notes
- 1 torch (see 'Preparation')

### FOR EACH TEAM

- role wristbands or badges for Director, Manager and Speaker
- each team member's science journal
- 1 copy of 'Shadow height investigation planner' (Resource sheet 9) per team member
- 1 copy of 'Measurement screen' (Resource sheet 10) per team member
- adhesive tac or double-sided adhesive tape
- 1 x 35 g glue stick
- 1 pencil
- 1 x 30 cm ruler
- 1 torch (see 'Preparation')

## Preparation

- Read 'How to write questions for investigation' (Appendix 5).
- Read 'How to conduct a fair test' (Appendix 6).
- Read 'How to construct and use a graph' (Appendix 7).
- Prepare an enlarged copy of 'Shadow height investigation planner' (Resource sheet 9).

**Note:** The type and size of torch used will impact the outcome of the investigation. Students using a smaller torch might have difficulty measuring the shadow at 5 cm (the beam of light won't be large enough to show the entire shadow). Additionally, if teams are using different types of torches then the measurements between teams will be different.

## Lesson steps



- 1 Review the previous lessons and discuss what students have learned about shadows. Ask questions, such as:
  - What is a shadow?
  - How can you make a shadow?
  - Why do shadows change in size?
  - Are shadows always the same size as the object that makes them?
  - Why can't you see your face in a shadow?

Record students' responses in the class science journal.



- 2 Introduce the torch and glue stick. Demonstrate the shadow of the glue stick made by the torch on the wall. Brainstorm the things (variables) that might affect the height of

the shadow and record students' answers on self-adhesive notes. For example:

- the distance from the torch to the glue stick
- the distance from the screen to the glue stick
- the angle of the torch
- the height of the glue stick
- the height of the torch
- the type of torch.



**3** Model how to develop a question for investigation. For example, we might choose to investigate 'What happens to the height of the shadow when we change the distance from the torch to the glue stick?' Introduce and explain the enlarged investigation planner and record the question.



**4** Discuss which of the variables will be changed, measured or kept the same in this investigation. For example:

- **Change:** the distance from the torch to the glue stick
- **Measure/observe:** the height of the shadow
- Keep the **same:** the position of the glue stick, the strength of the torch, the angle of the torch and the height of the glue stick.

Place the self-adhesive notes (variables) into the appropriate positions on the enlarged investigation planner.

		Light shows
<h3>Shadow height investigation planner</h3>		
Name: _____		Date: _____
Other members of your team: _____		
What are you going to investigate? <i>What happens to the height of the shadow when we change the distance from the torch to the glue stick?</i>	What do you predict will happen? Why?  	
Can you write it as a question?	Give scientific explanations for your prediction	
<b>To make this a fair test what things (variables) are you going to:</b>		
Change? <i>The distance from the torch to the glue stick</i>	Measure? <i>The height of the shadow</i>	Keep the same? <i>• the position of the glue stick</i> <i>• the torch</i> <i>• the angle of the torch</i> <i>• the glue stick</i>
Change only one thing	What would the change affect?	Which variables will you control?

Photo of enlarged planner

ELABORATE



5 Ask students why it is important to keep some things the same when conducting an investigation. (To keep things fair and so that we know what causes the changes.)

6 Explain that students will be working in collaborative learning teams to investigate the question: 'What happens to the height of the shadow when we change the distance from the torch to the glue stick?'



7 Form teams and allocate roles. Ask Managers to collect team equipment, including a copy of the 'Shadow height investigation planner' (Resource sheet 9) for each team member. Allow time for teams to complete the first page of their investigation planner.



8 As a class, discuss each team's investigation plan, their predictions of what they think might happen and the reasons for their predictions. For example:

- The nearer the torch to the glue stick, the taller the shadow because the torch beam becomes larger.
- The nearer the torch to the glue stick, the shorter the shadow because the torch beam becomes smaller.
- The shadow will be the same height no matter where the torch is because the glue stick has its own shadow.



9 Introduce and model how to use the ruler, the 'Measurement screen' (Resource sheet 10), the glue stick and the torch, and discuss how to measure and record in order to keep the investigation fair. For example:



- Fold under or cut off the lower margin of the 'Measurement screen' (Resource sheet 10) so that the zero mark will sit on the desk or floor.
- Fix 'Measurement screen' (Resource sheet 10) to a wall in a darkened area.
- Place the ruler against the wall. Measure and mark a line approximately 5 cm from the wall.
- Place the back of the glue stick on the 5 cm mark.
- Move the ruler to the front of the glue stick.
- Place the torch in the first position of 5 cm from the glue stick.
- Mark the height of the shadow on the screen. Students may round off to the nearest half centimetre.
- Record measurement on the table in the 'Shadow height investigation planner' (Resource sheet 9).
- Place the torch in the next position (10 cm from the front of the glue stick) and mark the height of the shadow on the screen.
- Continue this process for 15 cm, 20 cm, 25 cm and 30 cm from the glue stick.

**Note:** Some students might measure the umbra (darker shadow) and others might measure the penumbra (lighter shadow). Provided each group measures consistently this will not be a problem for their investigation. However, it might mean that results are quite different between groups.



10 Discuss ways to keep the investigation fair. Ask questions, such as:

- What would happen if we changed the glue stick and the distance from the torch to the glue stick? (We have changed two things so we don't know which one made the difference.)



- What if we change the angle of the torch each time? (If we change the angle and the distance between the torch and the glue stick we won't know which one made the difference.)



**11** Ask Managers to collect team equipment. Allow time for teams to set up and complete their investigations, recording their results in the table in the 'Recording and presenting results' section of the 'Shadow height investigation planner' (Resource sheet 9).

**Note:** Ask Managers to make sure the 30 cm ruler remains in place, Speakers to make sure that the torch is in the correct place each time and Directors to carefully mark the height of the shadow on the 'Measurement screen' (Resource sheet 10).



**Photo of investigation set up**



**12** Model for the class how to construct a graph to visually represent the information recorded in the table. Discuss the purpose and features of a graph.

**Literacy focus**

**Why do we use a graph?**

We use a **graph** to organise information so we can look for patterns. We use different types of graphs, such as picture, column, or line graphs for different purposes.

**What does a graph include?**

A **graph** includes a title, axes with labels on them and the units of measurement.

**ELABORATE**

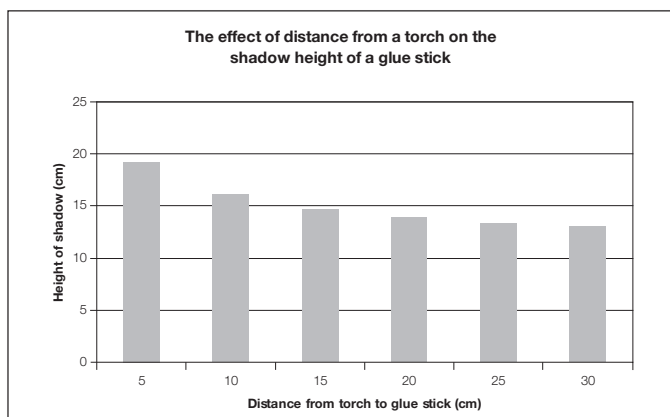

**Example of a graph**

Discuss with students the conventions of constructing a scientific graph. The vertical axis (Y axis) usually represents the thing (variable) we measure. In this investigation, this is the height of the shadow. The horizontal axis (X axis) represents the thing (variable) we change. In this investigation, this is the distance of the torch from the glue stick.

**Note:** As the data for both variables are continuous, a line graph would be the conventional method to represent findings from this investigation. It is suggested, however, that students construct a column graph as this is appropriate for Year 5 students. You might produce a column and a line graph and discuss with students why a line graph would normally be used to represent the data.



**13** After students have completed their graph using the findings from their investigation, analyse the graphs and look for patterns and relationships. Ask questions, such as:

- What is the story of your graph?
- When was the shadow tallest and shortest?
- Do the data in your graph reveal any patterns?



**14** Invite students to discuss their results, asking questions, such as:

- How did the height of the shadow change? (It got taller or shorter.)
- What did you notice about the position of the torch and the height of the shadow? (As the torch got closer to the glue stick the shadow got taller.)
- What do you predict will happen to the height of the shadow if the torch was 40 cm away from the glue stick? 60 cm?
- What can you say about the height of the shadow and the position of the torch?
- What can you say about shadows and light travelling in straight lines?



**15** Ask teams to discuss and complete the 'Explaining results' section of the 'Shadow height investigation planner' (Resource sheet 9).



**16** Provide students with time to reflect on the shadow height investigation and complete the 'Evaluating the investigation' section of the 'Shadow height investigation planner' (Resource sheet 9).

**17** Update the science chat-board and word wall with words and images.

## Curriculum links

### Science

- Investigate 'What will affect the shape of a shadow?'

### Mathematics

- Discuss rounding to the nearest half centimetre.
- Explore constructing and analysing graphs.
- Investigate measurement and number lines and how measurement starts at zero, not one.
- Discuss expressing units of measurement in abbreviated form.

# Shadow height investigation planner

Name: \_\_\_\_\_ Date: \_\_\_\_\_

Other members of your team: \_\_\_\_\_

<p>What are you going to investigate?</p>          <p>Can you write it as a question?</p>	<p>What do you predict will happen? Why?</p>          <p>Give scientific explanations for your prediction</p>
---	---

**To make this a fair test what things (variables) are you going to:**

<p>Change?</p>          <p>Change only one thing</p>	<p>Measure?</p>          <p>What would the change affect?</p>	<p>Keep the same?</p>          <p>Which variables will you control?</p>
--	---	---

<p>Describe how you will set up your investigation.</p>          <p>Use drawings if necessary</p>	<p>What equipment will you need?</p>          <p>Use dot points</p>
---	---

**Write and draw your observations in your science journal**

# Shadow height investigation planner

## Recording and presenting results

Record your results in a table.

Distance from torch to glue stick (cm)	Height of shadow (cm)
5	
10	
15	
20	
25	
30	

Present your results in a column graph.

Graph title: \_\_\_\_\_

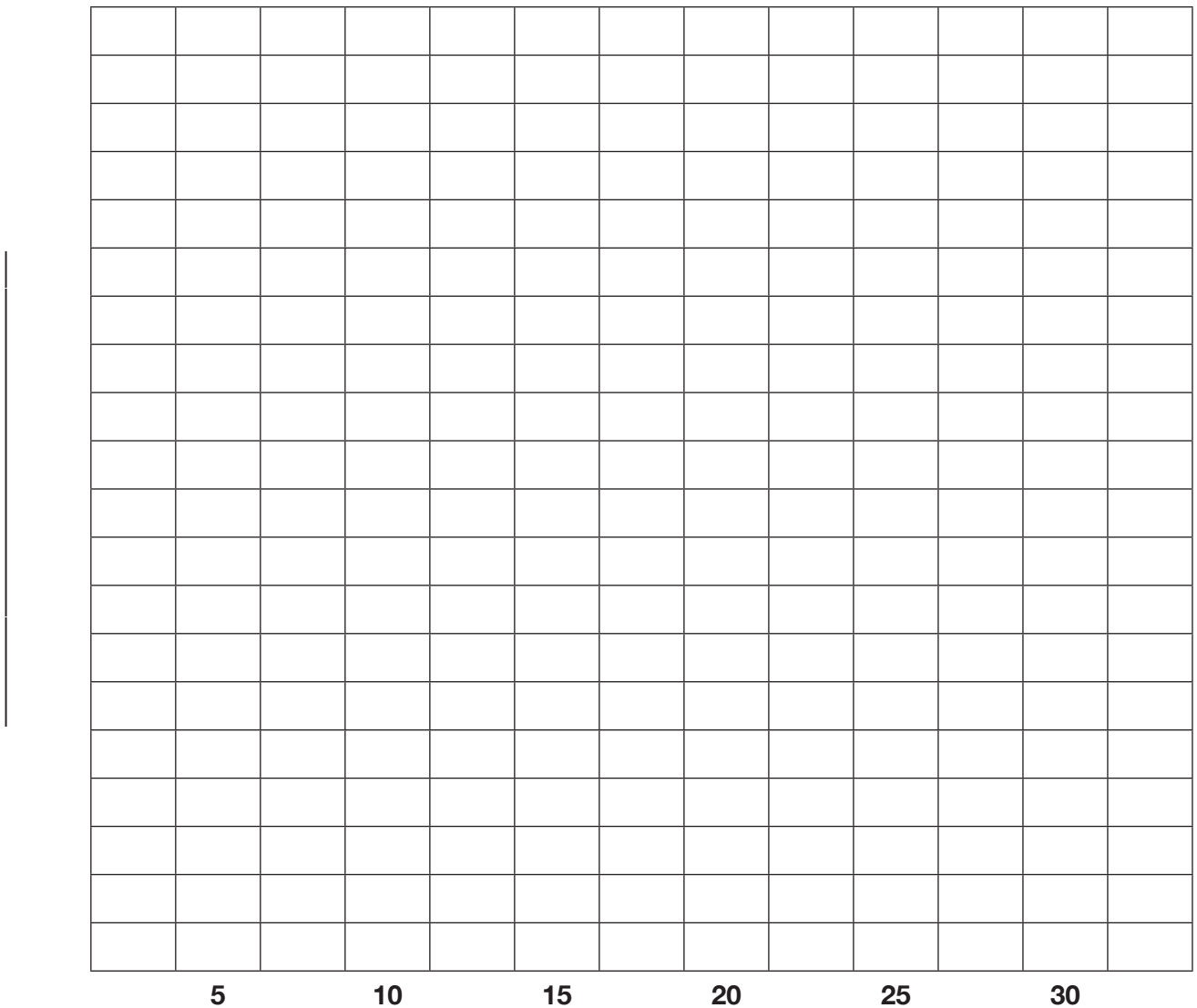

# Shadow height investigation planner

## Explaining results

What happened to the height of the shadow when you changed the distance from the torch to the glue stick?

Did the result match your prediction? Explain why and how it was different.

## Evaluating the investigation

What challenges did you experience doing this investigation?

How did you, or could you, overcome them?

How could you improve this investigation? (fairness/accuracy)

# Measurement screen



# Lesson 8 Light thoughts

## AT A GLANCE

To provide opportunities for students to represent what they know about how light from a source forms shadows and can be absorbed, reflected and refracted, and to reflect on their learning during the unit.

### Session 1 Light loop

Students:

- review this unit using the science chat-board, word wall and other resources developed throughout the unit
- participate in a word loop activity.

### Session 2 Shadow puppets

Students:

- create and perform a shadow play to represent their knowledge and understanding of light.

## Lesson focus

In the *Evaluate* phase students reflect on their learning journey and create a literacy product to re-represent their conceptual understanding.

## Assessment focus



**Summative assessment** of the Science Understanding descriptions is an important aspect of the *Evaluate* phase. In this lesson you will be looking for evidence of the extent to which students understand:

- how light from a source forms shadows and can be absorbed, reflected and refracted

## Key lesson outcomes

### Science

Students will be able to:

- match key vocabulary and scientific terms about light in a word loop
- describe how light helps us to see
- describe that light travels in straight lines until it hits an object
- describe how a shadow is formed
- describe transparent, translucent and opaque materials
- describe absorption, reflection and refraction.

### Literacy

Students will be able to:

- use scientific terms and key vocabulary to complete a word loop
- make an oral presentation as a shadow play to communicate their understanding about light.

This lesson also provides opportunities to monitor the development of students' general capabilities (highlighted through icons, see page 5).

## Session 1 Light loop

### Equipment

#### FOR THE CLASS

- class science journal
- science chat-board
- word wall
- 1 copy of 'Light shows word loop cards' (Resource sheet 11)
- self-adhesive notes

#### FOR EACH STUDENT

- science journal
- 1 copy of 'In the dark' (Resource sheet 2) (from Lesson 1, Session 2)

### Preparation

- Read 'How to use word loops' (Appendix 8) which includes the answer sheet.
- Cut out word loop cards.



## Lesson steps

- 1  Review with students the five questions on the science chat-board:
 





Question 1. How does light help us to see?

Question 2. How does light travel and how far does it travel?

Question 3. What is a shadow?

Question 4. What happens when light from a torch hits

  - black card?
  - a mirror?

Question 5. Draw what you see when a glass of water has a spoon in it.
- 2  Select volunteer students from the class to summarise the answers to each question on the science chat-board.
- 3  Review the tally sheet answers from 'In the dark' (Resource sheet 2, see Lesson 1, Session 2). Invite students to discuss the answers and explain which are scientifically accurate answers and which are inaccurate (Responses 1 and 5 are accurate). Ask students to provide reasons for their conclusions.
- 4  Review any other questions that have been posted onto the science chat-board during the unit. Discuss how students' ideas about light have changed and why, and what evidence they have used for their reasoning. Identify any questions they are still wondering about.
- 5  Introduce the word loop activity and organise students to complete the activity. After students have completed the word loop, organise the completed word loop cards for display on the science chat-board.

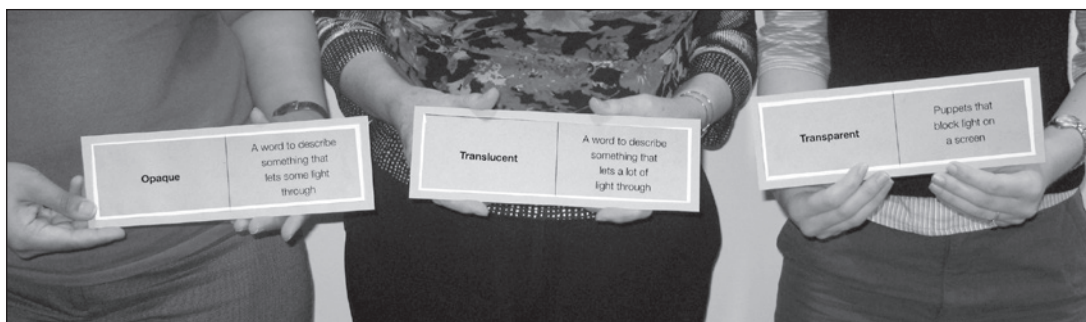

**Word loop activity**

# Session 2 Shadow puppets

## Equipment

### FOR THE CLASS

- class science journal
- science chat-board
- team roles chart
- team skills chart
- word wall
- self-adhesive notes
- overhead projector and screen

### FOR EACH TEAM

- role wristbands or badges for Director, Manager and Speaker
- each team member's science journal
- materials for making puppets (eg, thick cardboard, tape, scissors, popsticks, straws, glue, split pins)
- 1 torch
- transparent, translucent and opaque materials (eg, plastic cups, black paper, mirror)

## Lesson steps



- 1** Explain that as a reflection on their learning in this unit, students will be working in collaborative learning teams to use shadow puppets to present what they have learned about light. Explain to students that the shadow puppet presentation is to show their understanding about the five questions from the science chat-board:

Question 1. How does light help us to see?

Question 2. How does light travel and how far does it travel?

Question 3. What is a shadow?



Question 4. What happens when light from a torch hits

- black card?
- a mirror?

Question 5. Draw what you see when a glass of water has a spoon in it.



- 2** Before the students begin making their shadow puppets, encourage them to think about the following:
- How will you make your shadow puppets so that each has its own unique features when it casts its shadow?
  - How will you use the light and screen?
  - What materials will you make the puppets from?
  - How will using transparent, translucent and opaque materials/objects affect the puppets' shadows?
  - How will you hold and move the puppets?
  - If you want the shadows to change size, where will you need to hold them in relation to the light source?

- 3 Discuss with students the criteria for assessing students' presentations:
  - well-organised information
  - clear, concise communication
  - evidence of knowledge of the topic
  - use of evidence and reasoning to support conclusions
  - quality/creativity of the presentation.
- 4 Form teams and allocate roles. Ask Managers to collect team equipment.
-  5 Allow sufficient time for teams to prepare and perform shadow plays.
-  6 Provide time for students to reflect on their learning in the unit through peer and self-assessment of the five questions from the science chat-board.

## Curriculum links

### English

- Design a book about light for younger readers.
- Present the shadow plays to other classes.

### Mathematics

- Explore the properties of shapes. Discuss correspondence between shapes, sizes and locations of objects and their shadows.
- Make a series of action drawings in sequence to retell the shadow play story.

### Technology

- Create a shadow theatre.

### Studies of Society and Environment

- Explore the use of shadow puppets in traditional cultures, for example, Indonesian shadow puppets.

## Light shows word loop cards (1)

<b>Arrows</b>	A diagram that shows the path of light rays	<b>Ray diagram</b>	How far light travels
<b>Until something gets in its way</b>	The light source at the centre of our solar system	<b>The Sun</b>	A word to describe something that blocks light
<b>Opaque</b>	A word to describe something that lets some light through	<b>Translucent</b>	A word to describe something that lets a lot of light through
<b>Transparent</b>	When light bounces off a shiny surface	<b>Reflection</b>	Made when an object blocks light



## Light shows word loop cards (2)

<b>Shadow</b>	Light travels or reflects from an object to our....	<b>Eyes</b>	When light is bent as it passes from water to air
<b>Refraction</b>	Light sources on a car	<b>Headlights</b>	Reflects light
<b>Mirror</b>	How light travels	<b>Straight lines</b>	We cannot see without it
<b>Light</b>	A good light source to have to see in a dark room	<b>Torch</b>	A ray diagram needs these to show the direction light travels



# Appendix 1

## How to organise collaborative learning teams (Year 3–Year 6)

### Introduction

Students working in collaborative teams is a key feature of the PrimaryConnections inquiry-based program. By working in collaborative teams students are able to:

- communicate and compare their ideas with one another
- build on one another's ideas
- discuss and debate these ideas
- revise and rethink their reasoning
- present their final team understanding through multi-modal representations.

Opportunities for working in collaborative learning teams are highlighted throughout the unit.

Students need to be taught how to work collaboratively. They need to work together regularly to develop effective group learning skills.

The development of these collaborative skills aligns to descriptions in the Australian Curriculum: English. See page 7.

### Team structure

The first step towards teaching students to work collaboratively is to organise the team composition, roles and skills. Use the following ideas when planning collaborative learning with your class:

- Assign students to teams rather than allowing them to choose partners.
- Vary the composition of each team. Give students opportunities to work with others who might be of a different ability level, gender or cultural background.
- Keep teams together for two or more lessons so that students have enough time to learn to work together successfully.
- If you cannot divide the students in your class into teams of three, form two teams of two students rather than one team of four. It is difficult for students to work together effectively in larger groups.
- Keep a record of the students who have worked together as a team so that by the end of the year each student has worked with as many others as possible.

### Team roles

Students are assigned roles within their team (see below). Each team member has a specific role but all members share leadership responsibilities. Each member is accountable for the performance of the team and should be able to explain how the team obtained its results. Students must therefore be concerned with the performance of all team members. It is important to rotate team jobs each time a team works together so that all students have an opportunity to perform different roles.

For Year 3–Year 6, the teams consist of three students—Director, Manager and Speaker. (For Foundation–Year 2, teams consist of two students—Manager and Speaker.)

Each member of the team should wear something that identifies them as belonging to that role, such as a wristband, badge, or colour-coded peg. This makes it easier for you to identify which role each student is doing and it is easier for the students to remember what they and their team mates should be doing.

### **Manager**

The Manager is responsible for collecting and returning the team's equipment. The Manager also tells the teacher if any equipment is damaged or broken. All team members are responsible for clearing up after an activity and getting the equipment ready to return to the equipment table.

### **Speaker**

The Speaker is responsible for asking the teacher or another team's Speaker for help. If the team cannot resolve a question or decide how to follow a procedure, the Speaker is the only person who may leave the team and seek help. The Speaker shares any information they obtain with team members. The teacher may speak to all team members, not just to the Speaker. The Speaker is not the only person who reports to the class; each team member should be able to report on the team's results.

### **Director (Year 3–Year 6)**

The Director is responsible for making sure that the team understands the team investigation and helps team members focus on each step. The Director is also responsible for offering encouragement and support. When the team has finished, the Director helps team members check that they have accomplished the investigation successfully. The Director provides guidance but is not the team leader.

## **Team skills**

Primary**Connections** focuses on social skills that will help students work in collaborative teams and communicate more effectively.

Students will practise the following team skills throughout the year:

- Move into your teams quickly and quietly
- Speak softly
- Stay with your team
- Take turns
- Perform your role.

To help reinforce these skills, display enlarged copies of the team skills chart (see the end of this Appendix) in a prominent place in the classroom.

## **Supporting equity**

In science lessons, there can be a tendency for boys to manipulate materials and girls to record results. Primary**Connections** tries to avoid traditional social stereotyping by encouraging all students, irrespective of their gender, to maximise their learning potential. Collaborative learning encourages each student to participate in all aspects of team activities, including handling the equipment and taking intellectual risks.

Observe students when they are working in their collaborative teams and ensure that both girls and boys are participating in the hands-on activities.

# TEAM ROLES

## **Manager**

Collects and returns all materials the team needs

## **Speaker**

Asks the teacher and other team speakers for help

## **Director**

Make sure that the team understands the team investigation and completes each step



# TEAM SKILLS

- 1** Move into your teams quickly and quietly
- 2** Speak softly
- 3** Stay with your team
- 4** Take turns
- 5** Perform your role

## Appendix 2

### How to use a science journal

#### Introduction

A science journal is a record of observations, experiences and reflections. It contains a series of dated, chronological entries. It can include written text, drawings, labelled diagrams, photographs, tables and graphs.

Using a science journal provides an opportunity for students to be engaged in a real science situation as they keep a record of their observations, ideas and thoughts about science activities. Students can use their science journals as a useful self-assessment tool as they reflect on their learning and how their ideas have changed and developed during a unit.

Monitoring students' journals allows you to identify students' alternative conceptions, find evidence of students' learning and plan future learning activities in science and literacy.

Keeping a science journal aligns to descriptions in the Australian Curriculum: Science and English. See pages 2 and 7.

#### Using a science journal

- 1** At the start of the year, or before starting a science unit, provide each student with a notebook or exercise book for their science journal or use an electronic format. Tailor the type of journal to fit the needs of your classroom. Explain to students that they will use their journals to keep a record of their observations, ideas and thoughts about science activities. Emphasise the importance of including pictorial representations as well as written entries.
- 2** Use a large project book or A3 paper to make a class science journal. This can be used at all year levels to model journal entries. With younger students, the class science journal can be used more frequently than individual journals and can take the place of individual journals.
- 3** Make time to use the science journal. Provide opportunities for students to plan procedures and record predictions, and their reasons for predictions, before an activity. Use the journal to record observations during an activity and reflect afterwards, including comparing ideas and findings with initial predictions and reasons. It is important to encourage students to provide evidence that supports their ideas, reasons and reflections.
- 4** Provide guidelines in the form of questions and headings and facilitate discussion about recording strategies, such as note-making, lists, tables and concept maps. Use the class science journal to show students how they can modify and improve their recording strategies.
- 5** Science journal entries can include narrative, poetry and prose as students represent their ideas in a range of styles and forms.

- 6 In science journal work, you can refer students to display charts, pictures, diagrams, word walls and phrases about the topic displayed around the classroom. Revisit and revise this material during the unit. Explore the vocabulary, visual texts and ideas that have developed from the science unit, and encourage students to use them in their science journals.
- 7 Combine the use of resource sheets with journal entries. After students have pasted their completed resource sheets in their journal, they might like to add their own drawings and reflections.
- 8 Use the science journal to assess student learning in both science and literacy. For example, during the *Engage* phase, use journal entries for diagnostic assessment as you determine students' prior knowledge.
- 9 Discuss the importance of entries in the science journal during the *Explain* and *Evaluate* phases. Demonstrate how the information in the journal will help students develop literacy products, such as posters, brochures, letters and oral or written presentations.

### Light shows science journal

#### How does light travel?

I think Light  
travels FROM  
the wick in  
the Candle

Get the  
Wind

It reflects off the  
roof and bounces  
into the room

Light travels through the  
air and the oxygen

Light travels through  
the air and the  
oxygen.

## Appendix 3

### How to use a word wall

#### Introduction

A word wall is an organised collection of words and images displayed in the classroom. It supports the development of vocabulary related to a particular topic and provides a reference for students. The content of the word wall can be words that students see, hear and use in their reading, writing, speaking, listening and viewing.

The use of a word wall, including words from regional dialects and other languages, aligns to descriptions in the Australian Curriculum: English. See page 7.

#### Goals in using a word wall

A word wall can be used to:

- support science and literacy experiences of reading, viewing, writing and speaking
- provide support for students during literacy activities across all key learning areas
- promote independence in students as they develop their literacy skills
- provide a visual representation to help students see patterns in words and decode them
- develop a growing bank of words that students can spell, read and/or use in writing tasks
- provide ongoing support for the various levels of academic ability in the class
- teach the strategy of using word sources as a real-life strategy.

#### Organisation

Position the word wall so that students have easy access to the words. They need to be able to see, remove and return word cards to the wall. A classroom could have one main word wall and two or three smaller ones, each with a different focus, for example, high-frequency words.

Choose robust material for the word cards. Write or type words on cardboard and perhaps laminate them. Consider covering the wall with felt-type material and backing each word card with a self-adhesive dot to make it easy for students to remove and replace word cards.

Word walls do not need to be confined to a wall. Use a portable wall, display screen, shower curtain or window curtain. Consider a cardboard shape that fits with the unit, for example, a cactus in a desert for an adaptation unit.

The purpose is for students to be exposed to a print-rich environment that supports their science and literacy experiences.

Organise the words on the wall in a variety of ways. Place them alphabetically, or put them in word groups or groups suggested by the unit topic, for example, words for a *Light shows* unit might be organised using headings, such as 'Light sources' and 'How light travels'.

Invite students to contribute different words from different languages to the word wall. Group words about the same thing, for example, transparent, translucent and opaque, on the word wall so that the students can make the connections. Identify the different languages used, for example, by using different-coloured cards or pens to record the words.

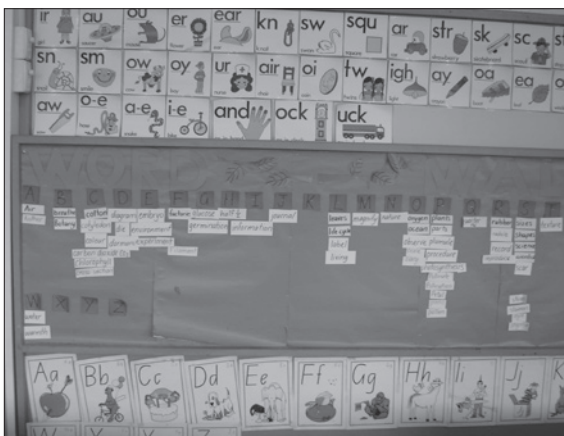

**Plants in action word wall**

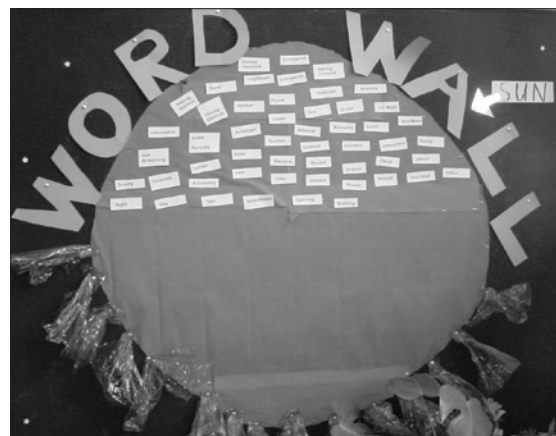

**Spinning in space word wall**

### Using a word wall

- 1 Limit the number of words to those needed to support the science and literacy experiences in the classroom.
- 2 Add words gradually, and include images where possible, such as drawings, diagrams or photographs. Build up the number of words on the word wall as students are introduced to the scientific vocabulary of the unit.
- 3 Encourage students to interact with the word wall. Practise using the words with students by reading them and playing word games. Refer to the words during science and literacy experiences and direct students to the wall when they need a word for writing. Encourage students to use the word wall to spell words correctly.
- 4 Use the word wall with the whole class, small groups and individually during literacy experiences. Organise multi-level activities to cater for the individual needs of students.

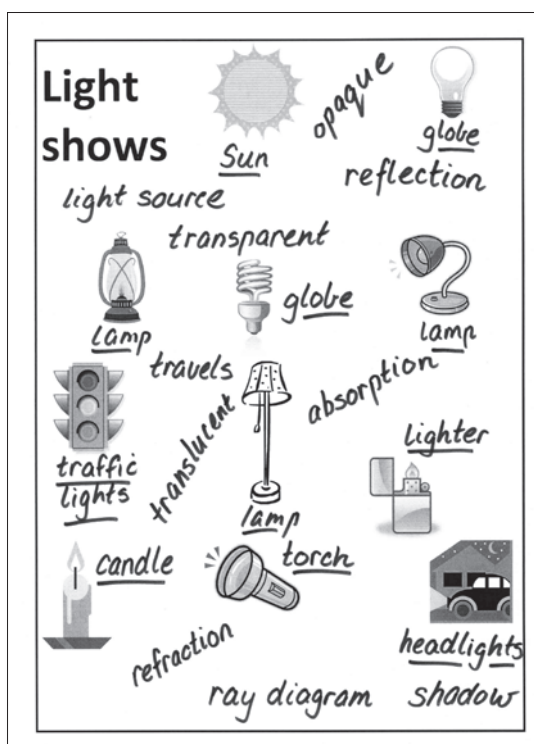

**Light shows word wall**

## Appendix 4

# How to facilitate evidence-based discussions

### Introduction

Argumentation is at the heart of what scientists do; they pose questions, make claims, collect evidence, debate with other scientists and compare their ideas with others in the field.

In the primary science classroom, argumentation is about students:

- articulating and communicating their thinking and understanding to others
- sharing information and insights
- presenting their ideas and evidence
- receiving feedback (and giving feedback to others)
- finding flaws in their own and others' reasoning
- reflecting on how their ideas have changed.

It is through articulating, communicating and debating their ideas and arguments that students are able to develop a deep understanding of science content.

### Establish norms

Introduce norms before starting a science discussion activity. For example,

- Listen when others speak.
- Ask questions of each other.
- Criticise ideas not people.
- Listen to and discuss all ideas before selecting one.

### Question, Claim, Evidence and Reasoning

In science, arguments that make claims are supported by evidence. Sophisticated arguments follow the QCER process:

- Q** What **question** are you trying to answer? For example, 'What happens to the height of the shadow when we change the distance from the torch to the glue stick?'
- C** The **claim**. For example, 'The nearer the torch to the glue stick, the taller the shadow.'
- E** The **evidence**. For example, 'We measured the size of the shadow each time we moved the glue stick closer to the screen. Our results were: 5 cm from the torch to the screen—the height of the shadow was 19.3 cm; 10 cm—16.1 cm; 15 cm—14.7 cm; 30 cm—13 cm.'
- R** The **reasoning**, saying how the evidence supports the claim, for example, 'Light travels in straight lines so the closer the object to the light source the more light it blocks out and therefore the bigger the shadow.'

Students need to be encouraged to move from making claims only, to citing evidence to support their claims. Older students develop full conclusions that include a claim, evidence and reasoning. This is an important characteristic of the nature of science and an aspect of scientific literacy. Using science question starters (see next section) helps to promote evidence-based discussion in the classroom.

## Science question starters

Science question starters can be used to model the way to discuss a claim and evidence for students. Teachers encourage team members to ask these questions of each other when preparing their claim and evidence. They might also be used by audience members when a team is presenting its results. (See PrimaryConnections 5Es DVD, Chapter 5).

### Science question starters

Question type	Question starter
<b>Asking for evidence</b>	I have a question about _____ . How does your evidence support your claim _____ ? What other evidence do you have to support your claim _____ ?
<b>Agreeing</b>	I agree with _____ because _____ .
<b>Disagreeing</b>	I disagree with _____ because _____ . One difference between my idea and yours is _____ .
<b>Questioning further</b>	I wonder what would happen if _____ ? I have a question about _____ . I wonder why _____ ? What caused _____ ? How would it be different if _____ ? What do you think will happen if _____ ?
<b>Clarifying</b>	I'm not sure what you meant there. Could you explain your thinking to me again?





## Q2: What happens to the height of the shadow when we change the angle of the torch?

In this question, *the height of the shadow* depends on *the angle of the torch*. The angle of the torch is the thing that is **changed** (independent variable) and the height of the shadow is the thing that is **measured or observed** (dependent variable).

### Developing questions for investigation

The process of developing questions for investigation in *Light shows* is to:

- Provide a context and reason for investigating.
- Pose a general focus question in the form of: ‘What things might affect \_\_\_\_\_ (**dependent variable**)?’.
- For example, ‘What things might affect the height of a shadow?’.
- Use questioning to elicit the things (**independent variables**) students think could affect the (**dependent variable**). For example, the distance between the glue stick and the torch, the angle of the torch, the height of the torch, the height of the glue stick, the type of torch).
- By using questions, elicit the things that students can investigate, such as the distance between the glue stick and the torch or the angle of the torch. These are the things that could be changed (**independent variables**), which students predict will affect the thing that is measured or observed (**dependent variable**).

Each of the independent variables can be developed into a question for investigation.

- Use the scaffold ‘What happens to \_\_\_\_\_ when we change \_\_\_\_\_?’ to help students develop specific questions for their investigation.
- Ask students to review their question for investigation after they have conducted their investigation and collected and analysed their information.
- Encouraging students to review their question will help them to understand the relationship between what was changed and what was measured in their investigation. It also helps students to see how the information they collected relates to their prediction.

## Appendix 6

### How to conduct a fair test

#### Introduction

Scientific investigations involve posing questions, testing predictions, collecting and interpreting evidence and drawing conclusions and communicating findings.

#### Planning a fair test

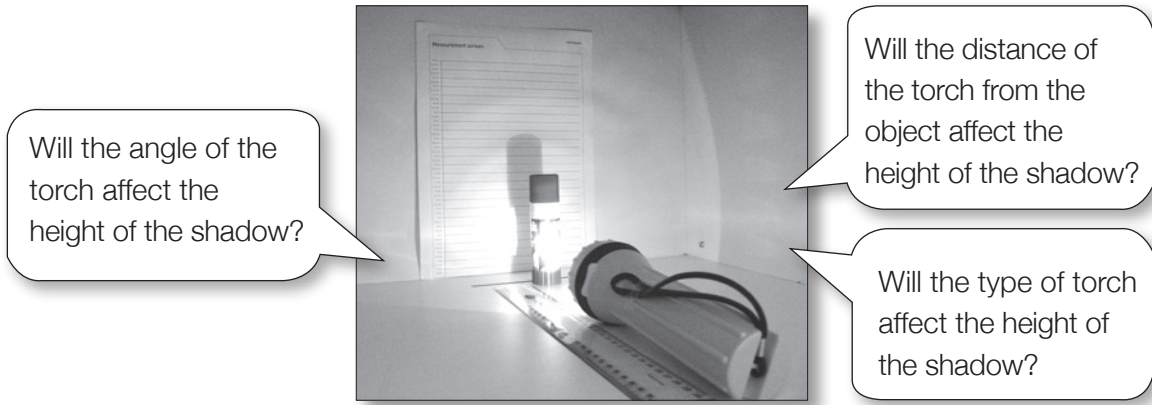

In *Light shows*, students investigate the things that affect the shadow height of an object.

All scientific investigations involve *variables*. Variables are things that can be changed (independent), measured/observed (dependent) or kept the same (controlled) in an investigation. When planning an investigation, to make it a fair test, we need to identify the variables.

It is only by conducting a fair test that students can be sure that what they have changed in their investigation has affected what is being measured/observed.

‘Cows Moo Softly’ is a useful scaffold to remind students how to plan a fair test:

- Cows:** **Change** one thing (independent variable)
- Moo:** **Measure/Observe** another thing (dependent variable) and
- Softly:** keep the other things (controlled variables) the **Same**.

To investigate if the angle of the torch affects the shadow height of an object, students could:

<b>CHANGE</b>	the distance from the torch to the glue stick	Independent variable
<b>MEASURE</b>	the height of the shadow of an object	Dependent variable
KEEP THE <b>SAME</b>	the position of the screen, the position of the glue stick, the position of the ruler, the strength of the torch, the angle and position of the torch and the height of the glue stick	Controlled variables

## Appendix 7

### How to construct and use a graph

#### Introduction

A graph organises, represents and summarises information so that patterns and relationships can be identified. Understanding the conventions of constructing and using graphs is an important aspect of scientific literacy.

During a scientific investigation, observations and measurements are made and measurements are usually recorded in a table. Graphs can be used to organise the data to identify patterns, which help answer the research question and communicate findings from the investigation.

Once you have decided to construct a graph, two decisions need to be made:

- What type of graph? and
- Which variable goes on each axis of the graph?

#### What type of graph?

The type of graph used depends on the type of data to be represented. Many investigations explore the effect of changing one variable while another is measured or observed.

#### Column graph

Where data for one of the variables are in **categories** (that is, we use **words** to describe it, for example, material) a **column graph** is used. Graph A below shows how the results for an investigation of the effect of material type on the amount of light that passes through it (**data in categories**) have been constructed as a **column graph**.

**Table A: The effect of material on the amount of light that passes through**

Material	Amount of light
plastic sheet	all
bubble wrap	almost all
tissue paper	most
paper	not much
cardboard	none
foil	none

**Graph A: The effect of material on the amount of light that passes through**

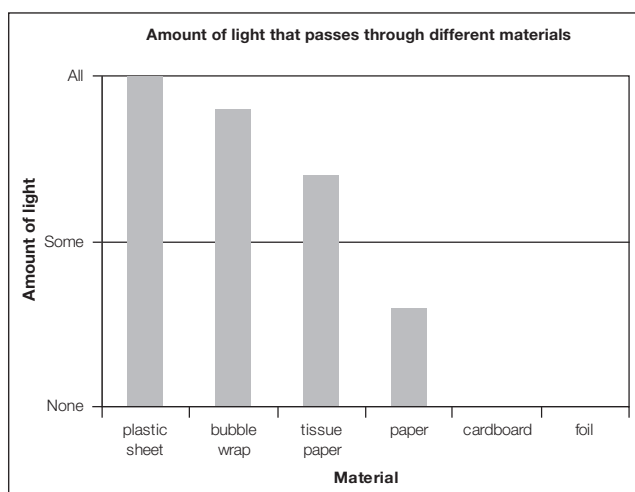

## Line graph

Where the data for both variables are **continuous** (that is, we use **numbers** that can be recorded on a measurement scale, such as length in centimetres or mass in grams), a **line graph** is usually constructed. Graph B below shows how the results from an investigation of the effect of distance from a light source (**continuous data**) on the shadow height of an object (**continuous data**) have been constructed as a **line graph**.

**Note:** For the ‘Big shadow, little shadow’ lesson in this unit, a line graph would be the conventional method to represent findings from this investigation as the data for both variables are continuous. It is suggested, however, that students construct a column graph as this is appropriate for Year 5 students. You might produce a column and a line graph and discuss with students why a line graph would normally be used to represent the data.

**Table B: The effect of distance from a torch on the shadow height of a glue stick**

Distance from torch to glue stick (cm)	Height of shadow (cm)
5	19.3
10	16.1
15	14.7
20	13.9
25	13.3
30	13

**Graph B: The effect of distance from a torch on the shadow height of a glue stick**

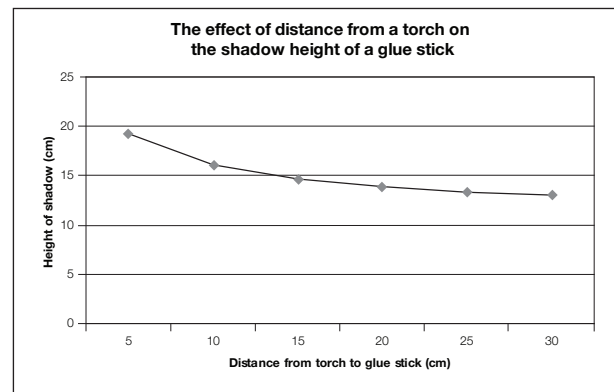

## Which variable goes on each axis?

It is conventional in science to plot the variable that has been changed on the horizontal axis (X axis) and the variable that has been measured/observed on the vertical axis (Y axis) of the graph.

## Graph titles and labels

Graphs have a title and each variable is labelled on the graph axes, including the units of measurement. The title of the graph is usually in the form of ‘The effect of one variable on the other variable’. For example, ‘The effect of distance from a torch on the shadow height of a glue stick’ (Graph B).

## Steps in analysing and interpreting data

- Step 1** – Organise the data (for example, construct a graph) so you can see the pattern in data or the relationship between data for the variables (things that we change, measure/observe, or keep the same).
- Step 2** – Identify and describe the pattern or relationship in the data.
- Step 3** – Explain the pattern or relationship using science concepts.

## Questioning for analysis

Teachers use effective questioning to assist students to develop skills in interrogating and analysing data represented in graphs. For example:

- What is the story of your graph?
- Do data in your graph reveal any patterns?
- Is this what you expected? Why?
- Can you explain the pattern? Why did this happen?
- What do you think the pattern would be if you continued the line of the graph?
- How certain are you of your results?

## Analysis

For example, analysis of Graph B shows that further the distance from the torch the shorter the height of the glue stick's shadow. This is because as light travels in straight lines, the closer the object to a light source the more light it blocks out and therefore the bigger the shadow.

## Appendix 8

### How to use word loops

#### Introduction

Word loops provide students with an opportunity to develop a deeper understanding of the scientific vocabulary of a PrimaryConnections unit. As students actively use the language of scientific ideas and concepts, their knowledge, understanding and confidence are enhanced.

A word loop is an activity that can be used when students are familiar with the vocabulary associated with the scientific ideas and concepts in the unit. Word loops can be developed from word walls or class science chat-boards, and involve matching words with their descriptions. The number of words can be increased during the unit with additional cards added as more words are introduced.

Word loops can be used as a ‘concept check’ activity at the beginning of a lesson, as a consolidation learning activity or, at the end of a lesson as a reflection or assessment activity.

#### Organisation

Word loops use a series of cards that have a description on the right-hand side and a scientific word or symbol on the left-hand side. The aim of the activity is to form a loop in which matching pairs of descriptions and words or symbols are made—similar to a game of dominoes.

Enlarge the *Light shows* ‘Word loop cards’ (Resource sheet 11) by photocopying onto card or heavy paper, and cut out the cards. The cards will last longer if they are laminated.

#### How to use word loops

- 1 Distribute word loop cards so each student or cooperative learning team has at least one card.
- 2 The teacher, or nominated student/s, starts the activity by reading aloud the statement on the right-hand side of their card, for example, ‘A ray diagram needs these to show the direction the light travels’.
- 3 The student/s who has the matching word or symbol on the left-hand side of their card indicates that they have the answer and reads it aloud, for example, ‘Arrows’.
- 4 The student/s with the matching word or symbol card moves to stand on the left-hand side of the person who read the matching description.
- 5 The word or symbol student then reads the description on the right-hand side of their card to continue the word loop.
- 6 This process continues until all the pairs have been matched up.

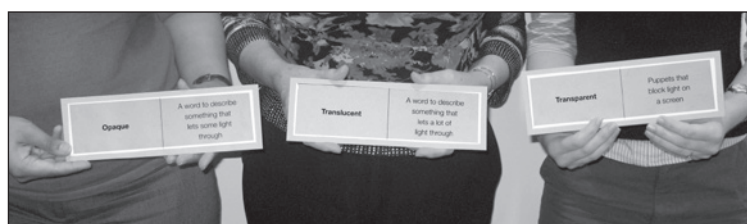

## Light shows word loop cards (Answers)

For the *Light shows* unit, the word loop card answers should be ordered as follows:

- 1 **Arrows:** A ray diagram needs these to show the direction light travels
- 2 **Ray diagram:** A diagram that shows the path of light rays
- 3 **Until something gets in its way:** How far light travels
- 4 **The Sun:** The light source at the centre of our solar system
- 5 **Opaque:** A word to describe something that blocks light
- 6 **Translucent:** A word to describe something that lets some light through
- 7 **Transparent:** A word to describe something that lets a lot of light through
- 8 **Reflection:** When light bounces off a shiny surface
- 9 **Shadow:** Made when an object blocks light
- 10 **Eyes:** Light travels or reflects from an object to our...
- 11 **Refraction:** When light is bent as it passes from air to water
- 12 **Headlights:** Light sources on a car
- 13 **Mirror:** Reflects light
- 14 **Straight lines:** How light travels
- 15 **Light:** We cannot see without it
- 16 **Torch:** A good light source to have to see in a dark room

## Appendix 9 Light shows equipment list

EQUIPMENT ITEM	QUANTITIES	LESSON		1	1	2	2	3	4	5	6	7	8	8
		SESSION	1	2	1	2	1	2	1	2	1	2	1	2
<b>Equipment and materials</b>														
adhesive tac or double sided adhesive tape	1 quantity per team											•		
batteries for torches optional	several per class					•								
blanket, opaque optional	1 per team							•						
book, thick	1 per team							•						
card, 20 cm x 20 cm	1 per team									•				
card (large pieces with a hole made in each) <i>optional</i>	1 set per class							•						
cardboard (eg, A4 sheets or cereal boxes)	1 collection per team										•			
cardboard box (eg, shoe or cereal box)	1 per class and 1 per team						•							
cup, plastic round and clear	1 per team													
glue	1 per team										•			
glue stick, 35 g	1 per class and 1 per team											•		
marking pens	1 set per team													
materials for making puppets (eg, thick cardboard, tape, scissors, popsticks, straws, glue, split pins, etc.)	1 collection per team													•
materials, samples (eg, clear plastic, baking or tissue paper, A4 paper, cardboard, bubble wrap, foil)	1 collection per class and per team									•				
materials, transparent, translucent, opaque (eg. clear plastic cups, black paper, mirror)	1 collection per team													•
mirrors	1 collection per class							•						
mirror, 8 cm x 5 cm approximately	1 per team							•						
mirror, 8 cm x 5 cm approximately	1 per student													•
objects (eg, metal spoons, coffee cups, glossy-surfaced books)	1 collection per class and per team							•						



EQUIPMENT ITEM	QUANTITIES	LESSON		1	1	2	2	3	4	5	6	7	8	8
		SESSION	1	2	1	2	1	2	1	2	1	2	1	2
<b>Equipment and materials</b>														
small objects (eg, toys)	1 collection per team					•								
card, 10 cm x 15 cm	3 pieces per team						•							
paper, large sheets (or cardboard)	1 per team	•												
paper, large sheets (or cardboard)	6 per class	•												
paper, butcher's large sheet	1 per team							•						
pencil	1 per team									•		•		
pencil	1 per class											•		
photographs and pictures (eg, from books, magazines or calendars) showing sunlight shining in straight lines	1 collection per class						•							
pipe, plastic approx. 30cm optional	1 piece per team						•							
ruler, 30 cm	1 per class and 1 per team									•		•		
ruler (or shadow puppet)	1 per class						•							
scissors	1 per team	•								•				
self-adhesive notes	several per class	•				•		•	•	•	•	•	•	•
self-adhesive tape	1 quantity per team								•		•			
shoeboxes or similar	5 per class	•												
talcum powder	1 quantity per class							•						
torch	1 per team					•		•	•	•		•		•
torch	1 per class	•				•		•				•		•
water	1 quantity per team									•				

EQUIPMENT ITEM	QUANTITIES	LESSON		1	1	2	2	3	4	5	6	7	8	8
		SESSION	1	2	1	2	1	2	1	2	1	2	1	2
<b>Resource sheets</b>														
'My thoughts' (RS1)	1 per student		•											
'My thoughts' (RS1), enlarged	1 per class		•											
'In the dark' (RS2)	1 per student			•									•	
'In the dark' (RS2), enlarged	1 per class			•										
'Passing through' (RS3)	1 per team								•					
'Passing through' (RS3), enlarged	1 per class								•					
'I can see the light' (RS4)	1 per team								•					
'I can see the light' (RS4), enlarged	1 per class								•					
'Line of light investigation planner' (RS5)	1 per student									•				
'Line of light investigation planner' (RS5), enlarged	1 per class									•				
'Exposing the illusion' (RS6)	1 per student									•				
'Exposing the illusion' (RS6), enlarged	1 per class									•				
'Periscope pieces' (RS7) (parts 1 & 2)	1 per student										•			
'Periscope pieces' (RS7) (parts 1 & 2)	1 per class										•			
'Periscope pal' (RS8)	1 per student										•			
'Periscope pal' (RS8), enlarged	1 per class										•			
'Shadow height investigation planner' (RS9)	1 per student											•		
'Shadow height investigation planner' (RS9), enlarged	1 per class											•		
'Measurement screen' (RS10)	1 per student												•	
'Measurement screen' (RS10)	1 per class												•	
'Light shows word loop cards' (RS13)	1 per class													•

EQUIPMENT ITEM	QUANTITIES	LESSON		1		2		3		4		5		6		7		8		
		SESSION	1	2	1	2	1	2	1	2	1	2	1	2	1	2	1	2		
<b>Teaching tools</b>																				
class science journal	1 per class	•	•	•	•	•	•	•	•	•	•	•	•	•	•	•	•	•	•	•
role wristbands or badges for Director, Manager and Speaker	1 set per team	•	•	•	•	•	•	•	•	•	•	•	•	•	•	•	•	•	•	•
science chat board	1 per class	•	•	•	•	•	•	•	•	•	•	•	•	•	•	•	•	•	•	•
student science journal	1 per student	•	•	•	•	•	•	•	•	•	•	•	•	•	•	•	•	•	•	•
team roles chart	1 per class	•	•	•	•	•	•	•	•	•	•	•	•	•	•	•	•	•	•	•
team skills chart	1 per class	•	•	•	•	•	•	•	•	•	•	•	•	•	•	•	•	•	•	•
word wall	1 per class	•	•	•	•	•	•	•	•	•	•	•	•	•	•	•	•	•	•	•
<b>Multimedia</b>																				
digital camera <i>optional</i>	1 per class										•									
overhead projector and screen	1 per class																			•

## Appendix 10 Light shows unit overview

		SCIENCE OUTCOMES*	LITERACY OUTCOMES*	LESSON SUMMARY	ASSESSMENT OPPORTUNITIES
		Students will be able to represent their current understanding as they:	Students will be able to:	Students will be able to:	
<b>ENGAGE</b>	<b>Lesson 1</b> Light ideas	<ul style="list-style-type: none"> <li>describe how light travels</li> <li>discuss how light enables our eyes to see</li> <li>describe and visually represent their understanding of reflection, absorption and refraction of light.</li> </ul>	<ul style="list-style-type: none"> <li>contribute to discussions about light and dark</li> <li>record ideas using a think-box strategy</li> <li>contribute to a science chat-board and word wall.</li> </ul>	<p>Students will be able to:</p> <p><b>Session 1</b> Illumination</p> <ul style="list-style-type: none"> <li>discuss what they think they know about light</li> <li>share ideas using a think-box strategy</li> <li>record ideas on the science chat-board</li> </ul> <p><b>Session 2</b> In the dark</p> <ul style="list-style-type: none"> <li>discuss being in the dark</li> <li>contribute ideas about what enables us to see.</li> </ul>	<p><b>Diagnostic assessment</b></p> <ul style="list-style-type: none"> <li>Science journal entries</li> <li>Class discussions</li> <li>Science chat-board and word wall contributions</li> <li>'My thoughts' (Resource sheet 1)</li> <li>'In the dark' (Resource sheet 2)</li> </ul>
	<b>Session 1</b> Illumination				
	<b>Session 2</b> In the dark				

\* These lesson outcomes are aligned to relevant descriptions of the Australian Curriculum. See page 2 for Science and page 7 for English and Mathematics.

	SCIENCE OUTCOMES*	LITERACY OUTCOMES*	LESSON SUMMARY	ASSESSMENT OPPORTUNITIES
<p><b>EXPLORE</b></p> <p><b>Lesson 2</b> Straight not crooked</p> <p><b>Session 1</b> Shining light</p> <p><b>Session 2</b> The travelling light show</p>	<p>Students will be able to:</p> <ul style="list-style-type: none"> <li>demonstrate how to modify a peek box to see an object</li> <li>describe how objects reflect light into our eyes allowing the objects to be seen</li> <li>draw a ray diagram to demonstrate that light travels in straight lines</li> <li>describe how a shadow is formed by blocking light.</li> </ul>	<p>Students will be able to:</p> <ul style="list-style-type: none"> <li>represent their thinking by using key vocabulary related to light</li> <li>understand the purpose and features of a ray diagram</li> <li>discuss observations of light and shadows</li> <li>understand the purpose and features of a labelled diagram</li> <li>record ideas about light and shadows.</li> </ul>	<p>Students will be able to:</p> <p><b>Session 1</b> Shining light</p> <ul style="list-style-type: none"> <li>make a peek box to demonstrate how we see objects</li> <li>draw a ray diagram showing how light travels through a peek box</li> </ul> <p><b>Session 2</b> The travelling light show</p> <ul style="list-style-type: none"> <li>compile a list of light sources</li> <li>explore how light travels in straight lines</li> <li>investigate the size and direction of shadows.</li> </ul>	<p><b>Formative assessment</b></p> <ul style="list-style-type: none"> <li>Science journal entries</li> <li>Class discussions</li> <li>Science chat-board and word wall contributions</li> <li>Ray diagrams</li> <li>Labelled diagrams</li> </ul>
<p><b>EXPLORE</b></p> <p><b>Lesson 3</b> Mirror, mirror</p>	<p>Students will be able to:</p> <ul style="list-style-type: none"> <li>identify that light travels in straight lines</li> <li>use mirrors to reflect light in different directions</li> <li>use ray diagrams to show the reflection of light by a mirror.</li> </ul>	<p>Students will be able to:</p> <ul style="list-style-type: none"> <li>discuss observations of how light travels</li> <li>record ideas about light travelling</li> <li>use talk to reason about how light travels</li> <li>extend vocabulary related to light.</li> </ul>	<p>Students will be able to:</p> <ul style="list-style-type: none"> <li>explore how to make light travel around a corner using mirrors</li> <li>use this knowledge to devise their own challenges.</li> </ul>	<p><b>Formative assessment</b></p> <ul style="list-style-type: none"> <li>Science journal entries</li> <li>Class discussions</li> <li>Science chat-board and word wall contributions</li> <li>Ray diagrams</li> </ul>

\* These lesson outcomes are aligned to relevant descriptions of the Australian Curriculum. See page 2 for Science and page 7 for English and Mathematics.

SCIENCE OUTCOMES*		LITERACY OUTCOMES*		LESSON SUMMARY		ASSESSMENT OPPORTUNITIES	
<b>EXPLORE</b>	<p><b>Lesson 4</b> Make way for the light</p> <p>Students will be able to:</p> <ul style="list-style-type: none"> <li>explore materials and how they affect light</li> <li>sort materials according to their ability to affect the path of light</li> <li>explain that light can be transmitted by a range of materials</li> <li>discuss the use of different materials for transmitting light</li> <li>sort materials into transparent, translucent and opaque categories.</li> </ul>	<p>Students will be able to:</p> <ul style="list-style-type: none"> <li>describe the amount of light passing through materials according to what can be seen through the material</li> <li>discuss observations of how light is affected by different materials</li> <li>use a table to sort and record information</li> <li>use talk to provide reasons for classifying materials into transparent, translucent and opaque categories.</li> </ul>	<p>Students will be able to:</p> <ul style="list-style-type: none"> <li>explore how the path of light is affected by different materials</li> <li>sort materials into transparent, translucent and opaque categories.</li> </ul>	<p><b>Formative assessment</b></p> <ul style="list-style-type: none"> <li>Science journal entries</li> <li>Class discussions</li> <li>Science chat-board and word wall contributions</li> <li>'Passing through?' (Resource sheet 3)</li> <li>I can see the light' (Resource sheet 4)</li> </ul>			
<b>EXPLORE</b>	<p><b>Lesson 5</b> Light illusions</p> <p>Students will be able to:</p> <ul style="list-style-type: none"> <li>explore transparent materials and how they affect the direction of light rays</li> <li>discuss and describe observations about refraction</li> <li>discuss uses of refraction and how light can be magnified through different objects</li> <li>test predictions by using evidence to develop explanations of illusions created by the refraction of light</li> <li>reflect on the investigation suggesting new variables to test.</li> </ul>	<p>Students will be able to:</p> <ul style="list-style-type: none"> <li>understand the purpose and features of a procedural text</li> <li>follow a procedural text to conduct an investigation</li> <li>discuss and compare results to form common understandings.</li> </ul>	<p>Students will be able to:</p> <ul style="list-style-type: none"> <li>explore the apparent distortion of objects when viewed through water</li> <li>work in teams to investigate light passing through a glass of water</li> <li>make claims about why objects appear distorted in water.</li> </ul>	<p><b>Formative assessment</b></p> <ul style="list-style-type: none"> <li>Science journal entries</li> <li>Class discussions</li> <li>Science chat-board and word wall contributions</li> <li>Labelled diagrams</li> <li>'Line of light investigation planner' (Resource sheet 5)</li> <li>'Exposing the illusion' (Resource sheet 6)</li> </ul>			

\* These lesson outcomes are aligned to relevant descriptions of the Australian Curriculum. See page 2 for Science and page 7 for English and Mathematics.

		SCIENCE OUTCOMES*	LITERACY OUTCOMES*	LESSON SUMMARY	ASSESSMENT OPPORTUNITIES
<b>EXPLAIN</b>	<b>Lesson 6</b> Sneaky spy	<p>Students will be able to:</p> <ul style="list-style-type: none"> <li>• identify sources of light</li> <li>• explain that light travels in straight lines</li> <li>• draw a ray diagram to explain how light from a source is reflected off an object into our eyes</li> <li>• construct a periscope to see an object around a corner.</li> </ul>	<p>Students will be able to:</p> <ul style="list-style-type: none"> <li>• represent the path of a light beam using a ray diagram</li> <li>• use scientific vocabulary when explaining how light travels.</li> </ul>	<p>Students will be able to:</p> <ul style="list-style-type: none"> <li>• construct a periscope to demonstrate light travelling in straight lines and being reflected</li> <li>• record and represent their understanding of light using a ray diagram and a written description.</li> </ul>	<p><b>Formative assessment</b></p> <ul style="list-style-type: none"> <li>• Science journal entries</li> <li>• Class discussions</li> <li>• Science chat-board and word wall contributions</li> <li>• ‘Periscope pal’ (Resource sheet 8)</li> </ul>
	<b>LABORATE</b>	<b>Lesson 7</b> Big shadow, little shadow	<p>Students will be able to:</p> <ul style="list-style-type: none"> <li>• conduct an investigation of the height of shadows showing awareness of a need for fair testing</li> <li>• explain how the height of a shadow can change by changing the distance from a light source to an object</li> <li>• identify variables affecting the height of shadows.</li> </ul>	<p>Students will be able to:</p> <ul style="list-style-type: none"> <li>• participate in discussions about variables that affect shadows</li> <li>• record findings in a table</li> <li>• identify the purpose and features of a graph</li> <li>• use a graph to represent findings.</li> </ul>	<p>Students will be able to:</p> <ul style="list-style-type: none"> <li>• work in teams to plan and set up an investigation of the height of shadows</li> <li>• measure the height of a shadow as the distance from the torch to the object changes</li> <li>• observe, record and interpret results</li> <li>• explain how a shadow is formed as a result of light travelling in straight lines.</li> </ul>

\* These lesson outcomes are aligned to relevant descriptions of the Australian Curriculum. See page 2 for Science and page 7 for English and Mathematics.

SCIENCE OUTCOMES*	LITERACY OUTCOMES*	LESSON SUMMARY	ASSESSMENT OPPORTUNITIES
<p>Students will be able to:</p> <ul style="list-style-type: none"> <li>• match key vocabulary and scientific terms about light in a word loop</li> <li>• describe how light helps us to see</li> <li>• describe that light travels in straight lines until it hits an object</li> <li>• describe how a shadow is formed</li> <li>• describe transparent, translucent and opaque materials</li> <li>• describe absorption, reflection and refraction.</li> </ul>	<p>Students will be able to:</p> <ul style="list-style-type: none"> <li>• use scientific terms and key vocabulary to complete a word loop</li> <li>• make an oral presentation as a shadow play to communicate their understanding about light.</li> </ul>	<p>Students will be able to:</p> <p><b>Session 1</b> Light loop</p> <ul style="list-style-type: none"> <li>• review this unit using the science chat-board, word wall and other resources developed throughout the unit</li> <li>• participate in a word loop activity</li> </ul> <p><b>Session 2</b> Shadow puppets</p> <ul style="list-style-type: none"> <li>• create and perform a shadow play to represent their knowledge and understanding of light.</li> </ul>	<p><b>Summative assessment</b> of Science Understanding</p> <ul style="list-style-type: none"> <li>• Science journal entries</li> <li>• Class discussions</li> <li>• Science chat-board and word wall contributions</li> <li>• Word loop</li> <li>• 'In the dark' (Resource sheet 2)</li> <li>• Oral presentations</li> </ul>
<p><b>EVALUATE</b></p>			

\* These lesson outcomes are aligned to relevant descriptions of the Australian Curriculum. See page 2 for Science and page 7 for English and Mathematics.



Order your next unit at  
[www.primaryconnections.org.au](http://www.primaryconnections.org.au)

Year	Biological sciences	Chemical sciences	Earth and space sciences	Physical sciences
F	<i>Staying alive</i>	<i>What's it made of?</i>	<i>Weather in my world</i>	<i>On the move</i>
1	<i>Schoolyard safari</i>	<i>Spot the difference</i>	<i>Up, down and all around</i>	<i>Look! Listen!</i>
2	<i>Watch it grow!</i>	<i>All mixed up</i>	<i>Water works</i>	<i>Push pull</i>
3	<i>Feathers, fur or leaves?</i>	<i>Melting moments</i>	<i>Night and day</i>	<i>Heating up</i>
4	<i>Plants in action</i>	<i>Material world</i>	<i>Beneath our feet</i>	<i>Smooth moves</i>
	<i>Friends and foes</i>	<i>Package it better</i>		
5	<i>Desert survivors</i>	<i>What's the matter?</i>	<i>Earth's place in space</i>	<i>Light shows</i>
6	<i>Marvellous micro-organisms</i>	<i>Change detectives</i>	<i>Earthquake explorers</i>	<i>It's electrifying</i>
				<i>Essential energy</i>

*PrimaryConnections: Linking science with literacy* is an innovative program linking the teaching of science with the teaching of literacy in primary schools.

The program includes a sophisticated professional learning component and exemplary curriculum resources.

PrimaryConnections features an inquiry-based approach, embedded assessment and incorporates Indigenous perspectives.

The PrimaryConnections curriculum resources span Years F–6 of primary school.

[www.primaryconnections.org.au](http://www.primaryconnections.org.au)

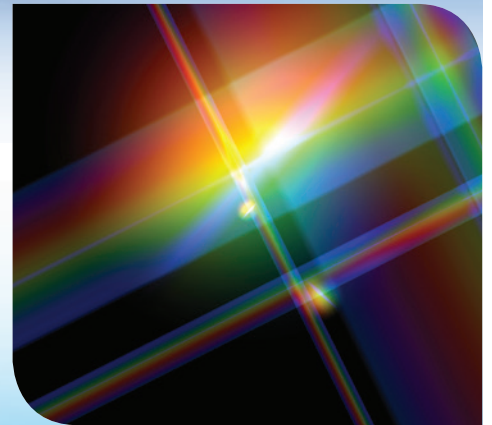

Australian Government



Australian Academy of Science

ISBN 978-0-85847-336-2



9 780858 473362